

Report

# Blenheim Sewage Treatment Plant Annual Consent Compliance Report - 1 July 2015 - 30 June 2016

**Prepared for Marlborough District Council (Client)**

**By CH2M Beca Limited**



30 August 2016



## Revision History

Revision N°	Prepared By	Description	Date
A	Lisa Mace	Draft for MDC review	29/08/2016
B	Lisa Mace	Final	30/08/2016

## Document Acceptance

Action	Name	Signed	Date
Prepared by	Lisa Mace		30/08/2016
Reviewed by	Sarah Burgess/Humphrey Archer		30/08/2016
Approved by	Graeme Jenner		30/08/2016
on behalf of	CH2M Beca Limited		

## Table of Contents

<b>1</b>	<b>Introduction .....</b>	<b>1</b>
1.1	Purpose of Report.....	1
1.2	Background.....	1
<b>2</b>	<b>Compliance with Consent U071181.....</b>	<b>3</b>
2.1	Consent Purpose .....	3
2.2	Reporting.....	3
2.3	Discharge to land .....	5
2.4	Discharge to Air.....	11
2.5	Discharge to Wairau Estuary .....	14
<b>3</b>	<b>Summary.....</b>	<b>22</b>
3.1	Overview .....	22
3.2	Compliance with Consent Conditions .....	22

## Appendices

**Appendix A – Consent U071181 including Site Plan and Monitoring Locations**

**Appendix B – Amended Consent Drawings and Condition 32(b) of U071181 prepared by CH2M Beca**

**Appendix C – Amended Consent Drawings and Minor Amendments to Condition 32 prepared by MDC**

**Appendix D – Annual Inspection of the MDC Wairau Bar Effluent Pipeline**

**Appendix E – Benthic Survey**

**Appendix F – Nitrogen Load to Land**

# 1 Introduction

## 1.1 Purpose of Report

The purpose of this report is to assess the compliance of the discharges from the Blenheim Sewage Treatment Plant (BSTP) with the conditions of Consent U071181, for the reporting period 1 July 2015 to 30 June 2016.

The BSTP and outfall sampling locations are shown in Consent U071181 which is included in **Appendix A**.

## 1.2 Background

Marlborough District Council (MDC) owns and operates the BSTP site at Hardings Road, which treats wastewater from residential and commercial premises (termed domestic flows), from within the Blenheim urban area, as well as industrial flows (mainly wineries).

### 1.2.1 Treatment Upgrading History

Prior to 2002, the BSTP consisted of a number of treatment ponds which treated domestic wastewater from Blenheim and industrial flows from Canterbury Meat Packers and the Riverlands Industrial Estate. The industrial ponds were formerly owned by the PPCS Meat Processing Plant, but were purchased by MDC in 2002, after the PPCS operation closed. The former PPCS factory site was subdivided and is now known as Cloudy Bay Business Park. Various new industries, including two wineries, have moved onto this site and the number of wineries in the Riverlands Industrial Estate has also increased.

From 2006 to 2008, MDC made a series of upgrades and changes to the treatment pond system to accommodate significant peak trade waste loads during the wine vintage, which occurs in the period March to May each year. The changes included diverting major industrial flows from the domestic to the industrial ponds, and increasing the aeration capacity of the industrial ponds in order to treat the increased load. Small trade waste discharges in Blenheim continue to contribute about 15% of the domestic flow into the BSTP.

MDC was granted consents in late 2010 to upgrade the BSTP treated wastewater disposal system. This upgrading (completed in February 2014), included the construction of a series of wetland cells which convey the combined treated flows from both the domestic and industrial pond systems, before discharging to a new outfall in the Wairau Estuary. The 1.6km long wetland system provides some further "polishing" treatment of the combined flows. Approximately 190ha of MDC-owned land around the BSTP is also available for wastewater irrigation on a soil moisture deficit basis from spring to autumn.

### 1.2.2 Current Treatment Systems

The BSTP consists of two separate treatment systems. A fine screen, as well as facultative and maturation ponds, are used to treat domestic flows while the industrial stream is treated using fine screening and mechanically aerated and facultative ponds. During the vintage, wastewater from the industrial ponds is redirected through twin DAF units for solids separation and recycling to create an activated sludge process.

Prior to February 2014, treated wastewater from the domestic system was continuously discharged to the Opawa River, and treated industrial flows were discharged to the Wairau Estuary on the ebb

tide. Historically, some industrial effluent from the now-closed PPCS Meat Processing Plant was applied to land during the summer months.

On 5 February 2014, discharge of treated wastewater from the domestic system to the Opawa River was ceased. The flow from Domestic Pond 5 is now conveyed to Pond 6 and combined with industrial wastewater before being discharged to the new wetland (Ponds 7-14). Treated wastewater is then discharged from Pond 14 to the Wairau Estuary via a new larger capacity outfall. The completed upgrade also includes land application of treated wastewater, when soil and groundwater conditions allow, via K-line irrigation and drip lines.

A schematic of the current treatment systems and combined estuarine discharge is shown in Figure 1-1.

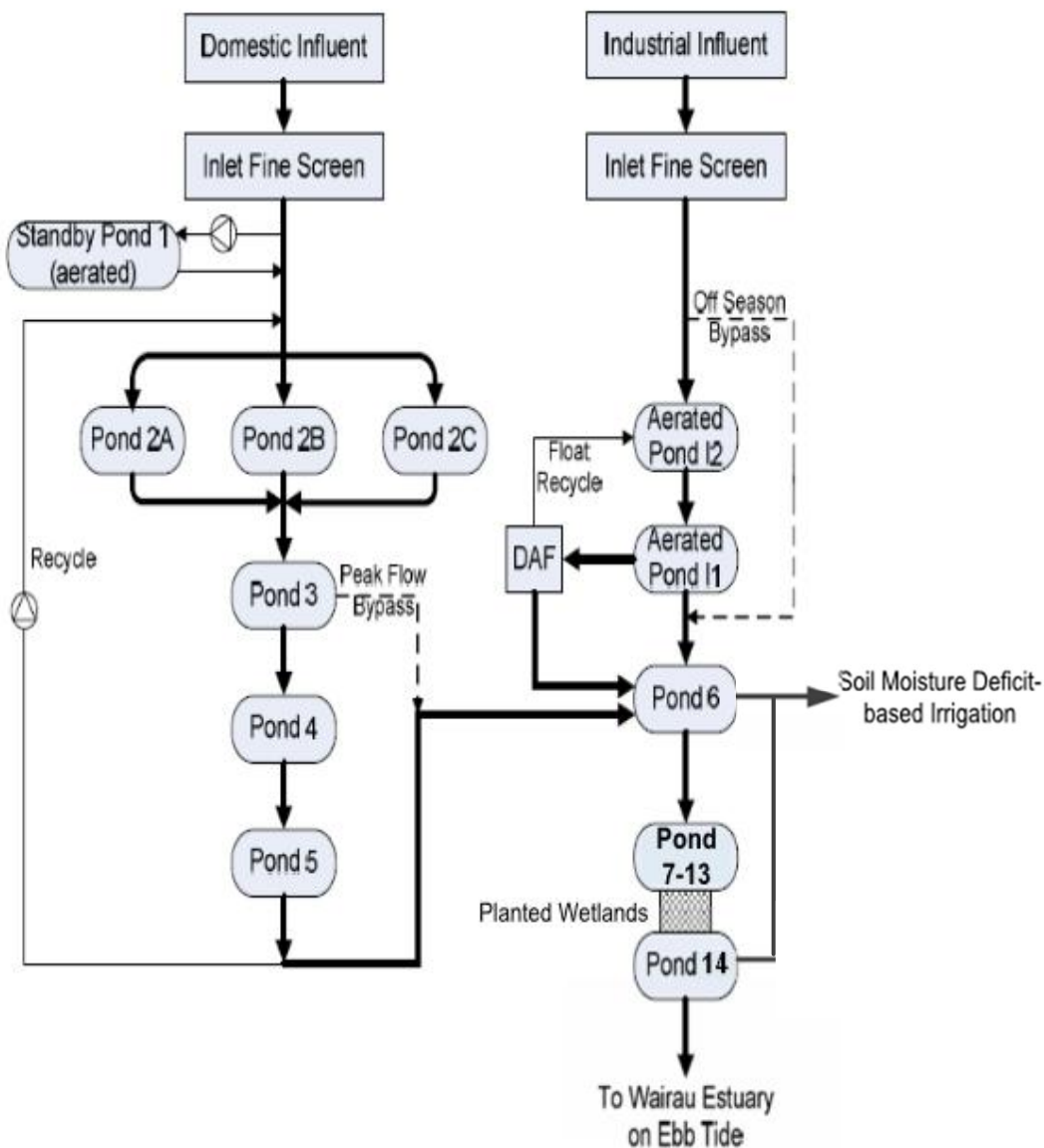

Figure 1-1 – BSTP Wastewater flow schematic (post-February 2014)

## 2 Compliance with Consent U071181

### 2.1 Consent Purpose

Consent U071181 authorises discharges from the BSTP treatment ponds to land, air and the Wairau Estuary. Some of the consent conditions do not have on-going monitoring requirements, and are not covered in this report. Only those conditions that have numerical or qualitative monitoring requirements are assessed. For clarity, consent conditions are quoted in *italics*, with other commentary in normal font.

### 2.2 Reporting

#### 2.2.1 Condition 7

*The Consent Holder shall provide to the Manager, Regulatory Department, Marlborough District Council, on or before 31 August in each year of the term of consent, from and including 2011, an Annual Monitoring Report (AMR) which must contain at least the following information:*

##### 7.1 General

*a) An analysis of the extent to which the Consent Holder has, in operating the BSTP and exercising these consents, complied with these Conditions of Consent and the extent and cause of any noncompliance, in each case with a summary of the environmental effects of the operation of the BSTP during the preceding 12 month period from 1 July- 30 June inclusive (the Reporting Period).*

This annual monitoring report (AMR) has been produced to achieve compliance with this condition.

*b) An identification and discussion of any operational difficulties, changes or improvements made to the wastewater treatment or operating processes, which would cause any material difference in environmental outcomes from the previous Reporting Period.*

This annual monitoring report (AMR) has been produced to achieve compliance with this condition.

*c) A comparison of results obtained over the Reporting Period with the results from previous reporting periods.*

Comparisons with previous years are noted in relevant sections of the report.

*d) An identification of any maintenance works needed, proposed or undertaken to ensure compliance with these Conditions of Consent.*

None identified.

*e) An identification of any improvements or changes required and the timetable for implementation.*

None identified.

##### 7.2 Discharge of Treated Wastewater to land

*a) The volume of treated wastewater applied to each of the Areas 1 – 3 (see **Appendix B** for the Proposed amended Consent Drawings and Condition 32(b) and **Appendix C** for the acceptance of these by MDC Regulatory Department)*

See Section 2.3.1.

*b) A summary and analysis (including graphical and statistical representations) of all data collected as a requirement of the Specific Conditions applicable to the discharge consent to discharge treated wastewater to land.*

See Section 2.3.1.

*c) A record and discussion of any complaints received regarding the discharge to land and the consent holder's response to those complaints.*

No complaints received. See Section 2.3.7.

*d) An analysis of any environmental effects, positive, neutral and adverse, which are attributable to the discharge of treated wastewater to land.*

See Section 2.3.

### *7.3 Discharge of Odour*

*a) Identification and discussion of any complaints received with respect to odour as per Condition 42 of the Discharge Permit to Air and any action taken to address the complaints.*

No complaints received. See Section 2.4.1.

*b) The measurements of Dissolved Oxygen (DO) concentrations as per Conditions 44 and 45 of the Discharge Permit to Air.*

See Sections 2.4.2 and 2.4.3.

*c) An analysis of the data in terms of consent compliance and environmental effects.*

See Sections 2.4.2 and 2.4.3.

*d) A discussion of any relevant operational changes or improvements carried out during the Reporting Period.*

None identified.

*e) A comparison of results in the Reporting Period to previous reporting periods and a discussion of any trends.*

Comparisons with previous years are noted in relevant sections of the report.

*f) Any complaints received in regard to the operation of the BSTP and the action(s) taken to address each complaint.*

No complaints received. See Section 2.4.1.

### *7.4 Wastewater Monitoring and Benthic and Water Quality Monitoring*

*a) A summary of all the monitoring data collected as a requirement of the conditions of the discharge permit to discharge treated wastewater to the Wairau Estuary during the Reporting Period.*

See Section 2.5.

*b) An analysis of the data in terms of consent compliance and environmental effects during the Reporting Period.*

See Section 2.5.

c) A discussion of any relevant operational changes or improvements carried out during the Reporting Period.

See Section 2.5.

d) A comparison of results with previous years and a discussion of any trends during the Reporting Period.

Comparisons with previous years are noted in relevant sections of the report.

e) Any complaints received in regard to the operation of the BSTP and the action(s) taken to address each complaint.

No complaints received.

### 7.5 Outfall Pipelines

a) A record of any maintenance works undertaken in accordance with Condition 52 of the Coastal Permit for the new and existing outfall pipelines.

This AMR addresses the requirements of Condition 7.

## 2.3 Discharge to land

### 2.3.1 Condition 7.2

Condition 7.2 requires that the AMR must include:

*The volume of treated wastewater applied to each of the Areas 1-3 (see **Appendix B** for the revised consent and **Appendix C** for MDC acceptance) in the reporting period.*

Table 2-1 shows the volume of treated wastewater and total application rate/ha that was discharged to each irrigation area.

**Table 2-1: Total Volume of treated wastewater discharged to each irrigation area (June 2014/ July 2015)**

Irrigation Area	Volume of Wastewater Applied (m <sup>3</sup> )	Area (ha)	Total application rate (m <sup>3</sup> /ha)
1	128,031	42	3,037
2	126,871	32	4,028
3	380,091	86	4,415

### 2.3.2 Condition 24

*The following net nitrogen loading limits shall be observed:*

a) *The maximum annual application of nitrogen shall not exceed a net loading of 200 kilograms of nitrogen per hectare per year.*

b) *Monthly applications shall not exceed a net loading of 50 kilograms of nitrogen per hectare.*



Treated wastewater from Pond 6 (some of which was recirculated from Pond 14) was used for irrigation between October 2015 and May 2016 when conditions were suitable. The mass of nitrogen applied to each irrigation segment during this period has been calculated based on the volumes applied and the nitrogen concentrations. The annual total nitrogen load for each segment is shown in **Appendix F**.

The average nitrogen load across all segments was 52.5 kg/ha. Segment KLA-06 Sth had the highest total load of 123.6 kg/ha. In all cases, the nitrogen application rates were lower than the consent limit of 200kg/ha/yr.

The highest monthly nitrogen application rate in occurred in March, when 33 kg per ha was applied to segment KLA-01 Sth. This is well below the consent limit of 50kg/ha/month.

### **2.3.3 Condition 29**

*Groundwater shall be sampled monthly while irrigation is occurring in each area identified in Plan Consent No A in Appendix 1 [see **Appendix B** for the revised consent and **Appendix C** for the MDC acceptance] to these conditions of consent, except that if irrigation has occurred for less than 14 days in the previous month no sampling is required. For each Irrigation Area, the wells identified within that area shown on Plan Consent No B attached in Appendix 1 [see **Appendix B** for the revised consent and **Appendix C** for the MDC acceptance] to these conditions of consent, shall be sampled. The samples shall be analysed for.*

*a) Ammoniacal nitrogen.*

*b) Nitrate nitrogen.*

*c) Conductivity.*

*d) E-coli.*

*The water level in each bore shall be measured and recorded at the time the sample is taken.*

Irrigation of treated wastewater occurred from October 2015 to May 2016. Samples were taken from each of the six wells between August 2015 and May 2016. The only exception was Well MSC-071 where no sample was collected in June 2016 due to vehicle issues.

The groundwater monitoring results (see Figures 2-1 to 2-3), show that all parameters tested were reasonably consistent over the monitoring period other than a spike in the E. coli concentration in one well (MSC-049), on 7 April 2016 (Figure 2-3). The vertical black lines on the figures show the time period that irrigation occurred for.

Electrical conductivity was also consistently high in Well 10031. This has been the case from the start of monitoring in 2015 onwards (Figure 2-2). As this well is located close to the tidally-influenced Opawa River, it is likely to contain higher salinity water (there is a strong relationship between conductivity and salinity).

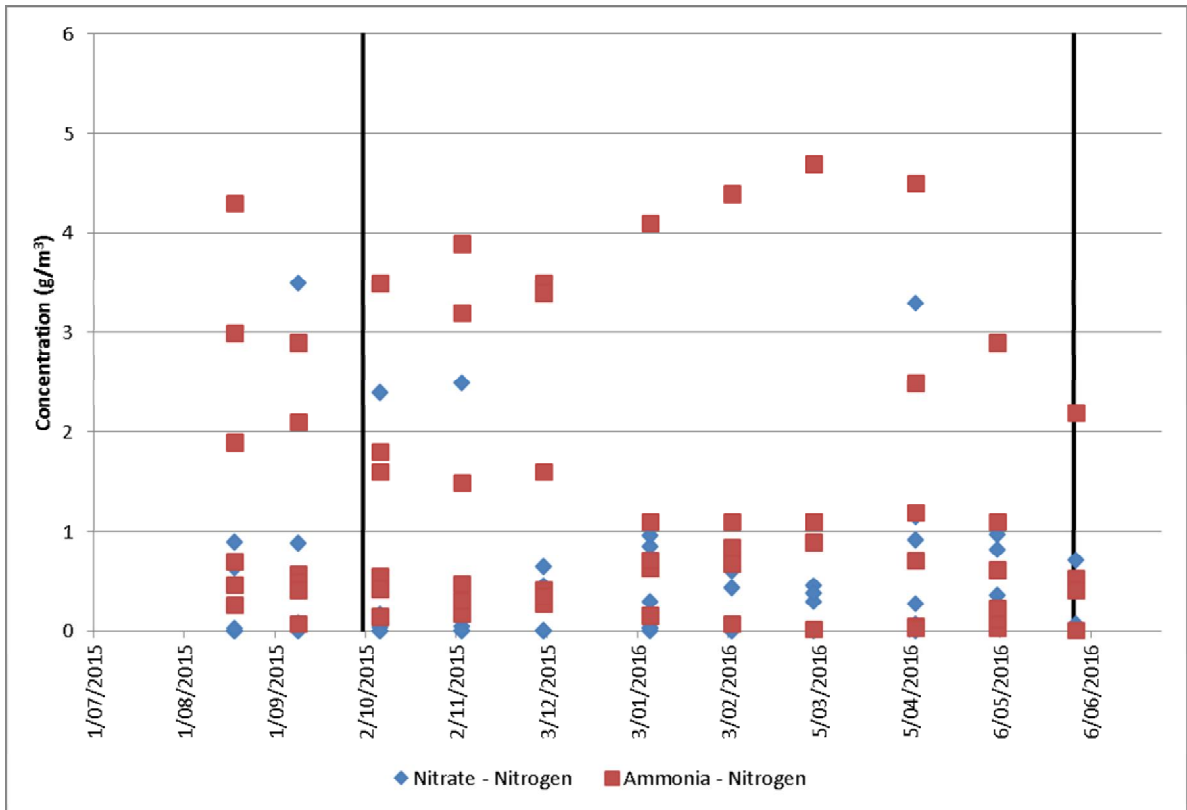

Figure 2-1: Groundwater testing results from six wells – Nitrate N and Ammoniacal N

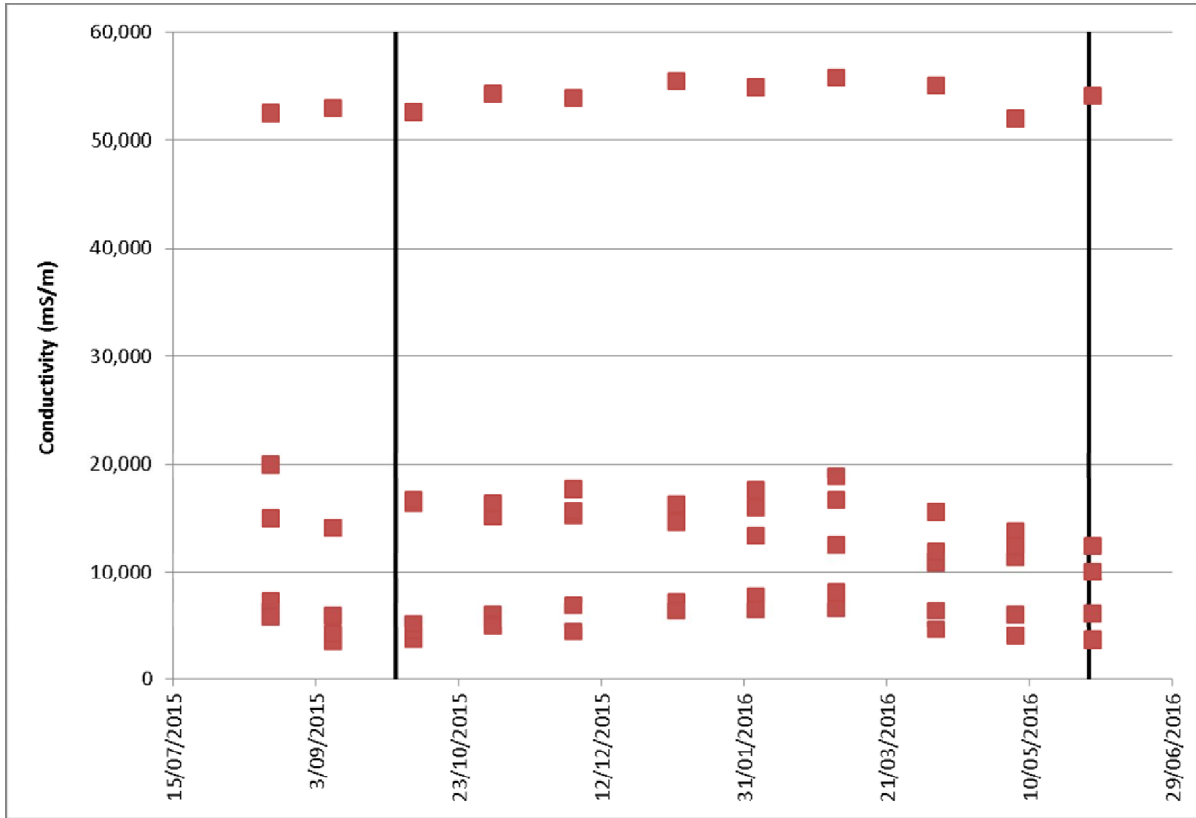

Figure 2-2: Groundwater testing results from six wells - electrical conductivity

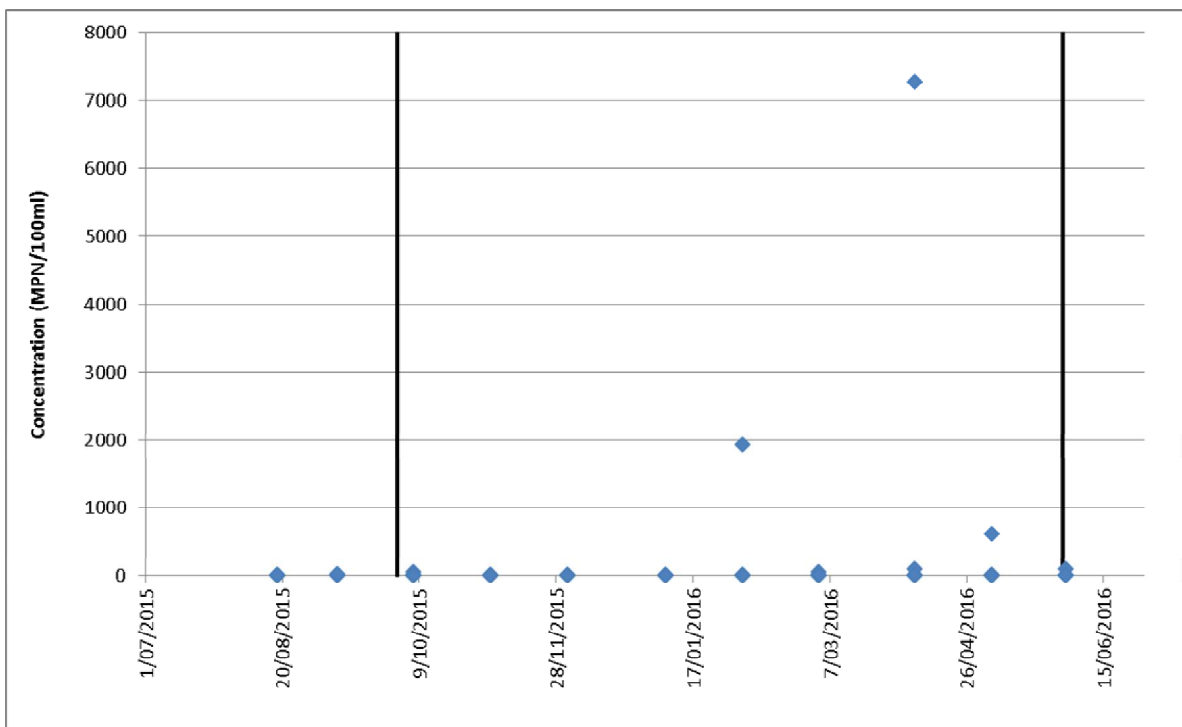

Figure 2-3: Groundwater testing results from six wells - E. coli

### 2.3.4 Condition 30

The groundwater level in the wells shown on Plan Consent No B attached in Appendix 1 [see **Appendix B** for the Revised Plan Consent and **Appendix C** for the MDC acceptance] to these conditions of consent shall be monitored prior to wastewater irrigation commencing and at least fortnightly thereafter while irrigation is occurring. If the groundwater level measured in any monitoring well, for a particular irrigation area, is closer than 0.3 metres from the ground surface, irrigation shall cease in that area. Irrigation shall not recommence until the groundwater level is greater than 0.3 metres below the ground surface.

As per Condition 30 of the consent, the groundwater levels were recorded and are shown in Table 2-2. Levels were recorded monthly, not fortnightly as required by the consent. One well level was not recorded in June due to vehicle issues but this was after irrigation had ceased. Only one of the measured levels was less than the consent irrigation cut-off requirement of 0.3 m below the ground surface. This occurred in June 2016 prior to irrigation commencing (see Column 3 of Table 2-2). All groundwater depths measured, during the period October 2015 to May 2016, were greater than 0.3 m below ground.

**Table 2-2: Recorded groundwater levels**

Date	Depth to groundwater (m)					
	MSC-049	MSC-055	MSC-070	MSC-071	10027	10031
7/10/2015	0.953	0.45	0.69	1.1	1.36	1.74
4/11/2015	1.48	1	0.9	1.48	1.45	1.75
2/12/2015	2.3	1.4	1.6	2.2	1.86	2
7/01/2016	2.3	1.47	1.53	2.4	1.95	1.88
4/02/2016	2.3	1.08	1.65	2.46	1.85	1.65
3/03/2016	2.35	1.2	2.15	2.7	2.1	1.95
7/04/2016	2.05	0.86	0.81	1.97	1.67	1.55
5/05/2016	2.4	0.95	0.85	2.02	1.65	1.9
1/06/2016	1.2	0.8	<b>0.2</b>	1.65	1.3	-

### 2.3.5 Condition 31

The potable water in well P28/4446 and one well on Lot 2 DP12207 shall be monitored as follows:

c) Sampling of both wells shall continue at monthly intervals during the wastewater irrigation season with a final sample being taken no later than 30 days after wastewater irrigation ceases each season.

d) Sampling shall continue for a period of 5 years after wastewater irrigation commences. If *E. coli* are detected then the sampling shall continue for a further 5 years from that time.

As per the consent requirements, potable water from Wells P28w/4447 and P28w/4446 was tested monthly during the reporting period (see Table 2-3). All E. coli results received were <1 cfu/100 ml and therefore no further action is considered necessary.

**Table 2-3: Potable Water Monitoring - E. Coli Concentration (cfu/100 ml)**

Date	p28w/4446	p28w/4447
3/07/2015	<1	<1
11/08/2015	<1	<1
10/09/2015	<1	<1
13/10/2015	<1	<1
3/11/2015	<1	<1
18/11/2015	<1	<1
9/12/2015	<1	<1
14/01/2016	<1	<1
10/02/2016	<1	<1
8/03/2016	<1	<1
7/04/2016	<1	<1
10/05/2016	<1	<1
9/06/2016	<1	<1

### 2.3.6 Condition 32

Condition 32a and b have been revised (as proposed in **Appendix B** and accepted by MDC Regulatory in **Appendix C**). The condition is now as follows:

*Prior to commencing the discharge;*

*a) A weather station shall be installed at the office building shown on Plan Consent No B attached in Appendix 1 [see **Appendix B** for the Revised Plan Consent and **Appendix C** for the MDC acceptance] to these conditions of consent. The weather station shall measure and record wind speed and direction and rainfall and have sufficient instrumentation to allow calculation of evapotranspiration. The wind speed and direction recorded at the weather station shall be deemed to represent the wind speed and direction for Areas 1 and 2.*

b) *An anemometer and wind vane shall be installed at the location shown as Wind Measurement Site (Area 3) on Plan Consent No B attached in Appendix 1 [see **Appendix B** for the Revised Plan Consent and **Appendix C** for the MDC acceptance] to these conditions of consent. The anemometer and wind vane shall measure and record wind speed and direction. The wind speed and direction recorded shall be deemed to represent the wind speed and direction for Irrigation Area 3.*

c) *The weather station, anemometers and wind vanes shall be maintained in an operational condition throughout the term of this consent.*

The two weather stations are set up and operating in accordance with the requirements of Condition 32.

### **2.3.7 Condition 35**

*The Consent Holder shall maintain a register of any complaints received relating to any aspect of the land discharge system. The record shall include the date and time of complaint, cause of the complaint, weather conditions at the time of complaint and action taken in response to the complaint. The register shall be made available to the Manager, Regulatory Department, Marlborough District Council, on request. A summary of complaints received by the consent holder shall be included in the AMR required by Condition 7.*

As no complaints were received during the reporting period, compliance with the requirements of Condition 35 was achieved.

### **2.3.8 Condition 36**

*For the duration of these consents, the Consent Holder shall install and maintain appropriate signage on any access points to the BSTP warning that partially treated wastewater is discharged to the land. Written confirmation of the signage wording, size and placement shall be provided to the Manager, Regulatory Department, Marlborough District Council, within three months of the commencement of this consent.*

Signage has been installed according to the requirements of Condition 36.

## **2.4 Discharge to Air**

### **2.4.1 Condition 42**

*Any complaints received in regard to odour shall be recorded in a Complaints Register specifying the complaint, time and date, weather conditions and action required. A copy of the complaints shall be made available to the Manager, Regulatory Department, Marlborough District Council, on request. A summary of these complaints shall be part of the AMR required by Condition 7 of these Conditions of Consent*

As no complaints were received during the reporting period, compliance with the requirements of Condition 42 was achieved.

### **2.4.2 Condition 44**

*The Consent Holder shall measure the Dissolved Oxygen (DO) concentrations in the wastewater near the outlet of Ponds 2A, 2B, 2C, 6 and 10 every Wednesday, except when a Wednesday falls on a public holiday, when the measurement shall be taken on the nearest following working day. The DO concentration shall be measured between 11 am and 2pm and shall not be less than 2 grams of DO per cubic metre, on a rolling 10 percentile weekly measurement basis.*

Figure 2-4 shows the weekly DO results for the reporting period and Table 2-4 summarises these results in relation to the consent limit. The DO concentration was measured in Pond 14 instead of Pond 10, as this is now the final wetland cell before discharge to the Estuary. Samples were generally taken weekly but they were not consistently taken on Wednesdays. Figure 2-4 shows that DO concentrations in the domestic pond (Ponds 2A, 2B and 2C), remained high and Table 2-4 shows that consent DO limits were being met in all ponds sampled.

Samples were not always taken within 11am and 2pm as required by the condition. As solar radiation (and therefore algal photosynthesis), is usually greatest between 11am and 2pm, pond DO concentrations should be always measured (for compliance purposes), during this period. It is recommended that operators measure DO concentration between 11am and 2pm to be in accordance with the condition.

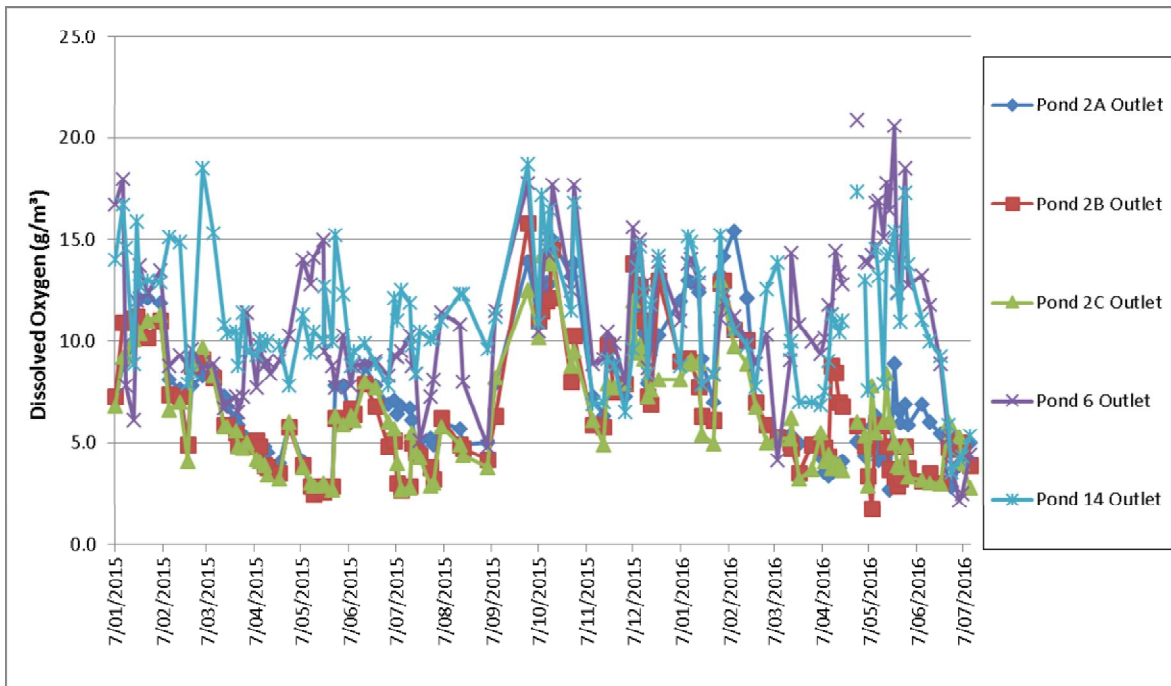

**Figure 2-4: Dissolved oxygen monitoring results at the outlet of Ponds 2A, 2B, 2C, 6 and 14**

**Table 2-4: Comparison of dissolved oxygen monitoring results for Ponds 2A, 2B, 2C, 6 and 14 with consent limit**

	10 <sup>th</sup> percentile
<b>Consent Limit</b>	<b>&gt;2.0g/m<sup>3</sup></b>
Pond 2A	3.9
Pond 2B outlet	3.2
Pond 2C outlet	3.0
Pond 6 outlet	7.3
Pond 14 outlet	7.5

### 2.4.3 Condition 45

*The DO of the wastewater in Ponds I1 and I2 shall be measured daily between 11am and 2pm during peak loading periods associated with the annual vintage, with DO concentrations maintained at not less than 0.5 grams per cubic metre on a 50 percentile basis. The time of the peak loading periods shall be determined by consultation between the Consent Holder and the Manager, Regulatory Department, Marlborough District Council. The results of the measurements shall be included in the AMR required by Condition 7.*

The annual peak vintage period occurs between March and May. Probes record DO concentrations in Ponds I1 and I2 every six minutes over this period. Daily average DO concentrations recorded between 11am and 2pm each day are shown in Figure 2-5. This figure shows that average daily DO concentrations in Pond I2 dropped to zero around 20 April 2016, at a time which coincided with peak BOD loading. However, as shown in Table 2-5, the 50<sup>th</sup> percentile DO concentration in both industrial ponds was well above the 0.5 g/m<sup>3</sup> required by the consent during the vintage period.

A drop in DO concentration to near zero in Pond I2 was also seen in April 2015 but this was assumed to be as a result of a power cut that occurred at the same time and stopped the aerators. There is no record of a power cut having occurred in April 2016. The drop in DO appears therefore, to be a result of the high influent BOD load. Regardless, this does not appear to have adversely affected DO concentrations downstream in Pond 6, as shown in Figure 2-4. This is assumed to be due to the larger volume of Pond 6 providing a buffer against the incoming low DO wastewater, and good BOD reduction in Ponds I1 and I2.



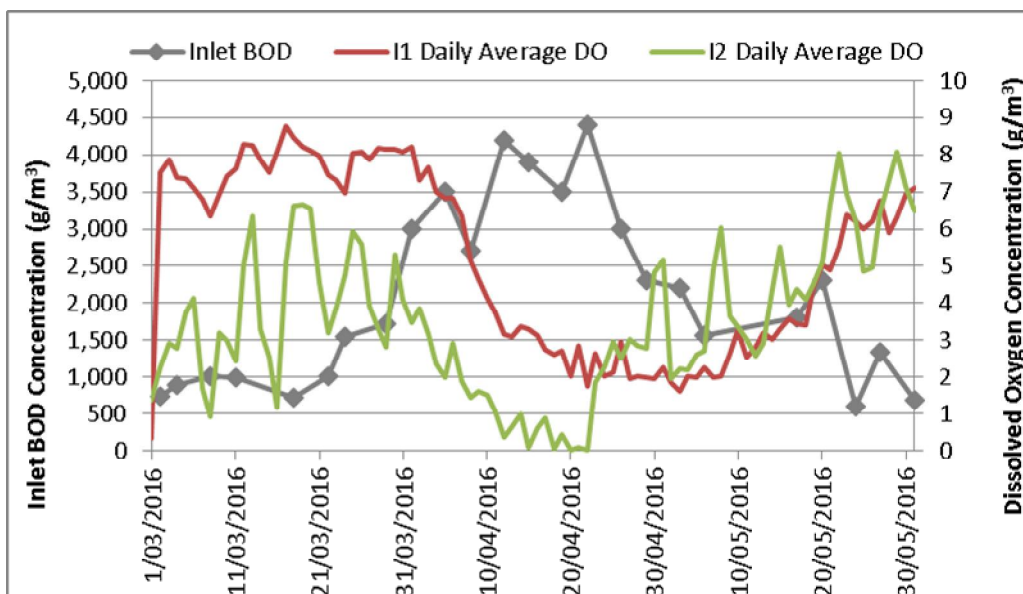

Figure 2-5: Dissolved oxygen daily averages in Ponds I1 and I2 compared to inlet BOD concentration

Table 2-5: Dissolved oxygen monitoring results for Ponds I1 and I2

	50 <sup>th</sup> percentile during peak period
Consent Limit	>0.5g/m <sup>3</sup>
Pond I1	5.7
Pond I2	3.2

## 2.5 Discharge to Wairau Estuary

### 2.5.1 Condition 51

The Consent Holder shall undertake annual external visual inspections of the outfall pipeline structures for the duration of the consent. A report shall be submitted to the Manager, Regulatory Department, Marlborough District Council, within 20 working days of the inspection being carried out. The report shall include but not be limited to:

- a) The date and time of the inspection.
- b) The condition of the outfall structures.
- c) Any maintenance work that may be required, and if it is required, when the work will be carried out

An inspection of the outfall pipeline was carried out during the 2015/2016 monitoring period (see report by N-VIRO Mooring Systems in **Appendix D** dated 26<sup>th</sup> February 2016). The overall condition of the outfall structures was noted to be good and no maintenance work was recommended.

### 2.5.2 Condition 54

*The existing buoy marking the location of the end of the existing outfall shall be marked with the words **Sewer Outfall** and the lettering used shall be bold and clear such that it can easily be read from a distance of 10 metres.*

The existing marker buoy has been marked according to the requirements of the condition.

### 2.5.3 Condition 55

*The total discharge of treated wastewater authorised by this consent shall not exceed an average daily volume of 28,500 cubic metres, where the average volume is calculated on a continuous basis over a period of 365 consecutive days. The maximum discharge volume per day shall not exceed 103,680 cubic metres.*

The daily treated wastewater discharge volume to the Wairau Estuary is shown in Figure 2-6. The average discharge volume over the monitoring period was 11,078 m<sup>3</sup>/day while the maximum volume was 28,285 m<sup>3</sup>/day. These volumes are both well below their respective consent limits.

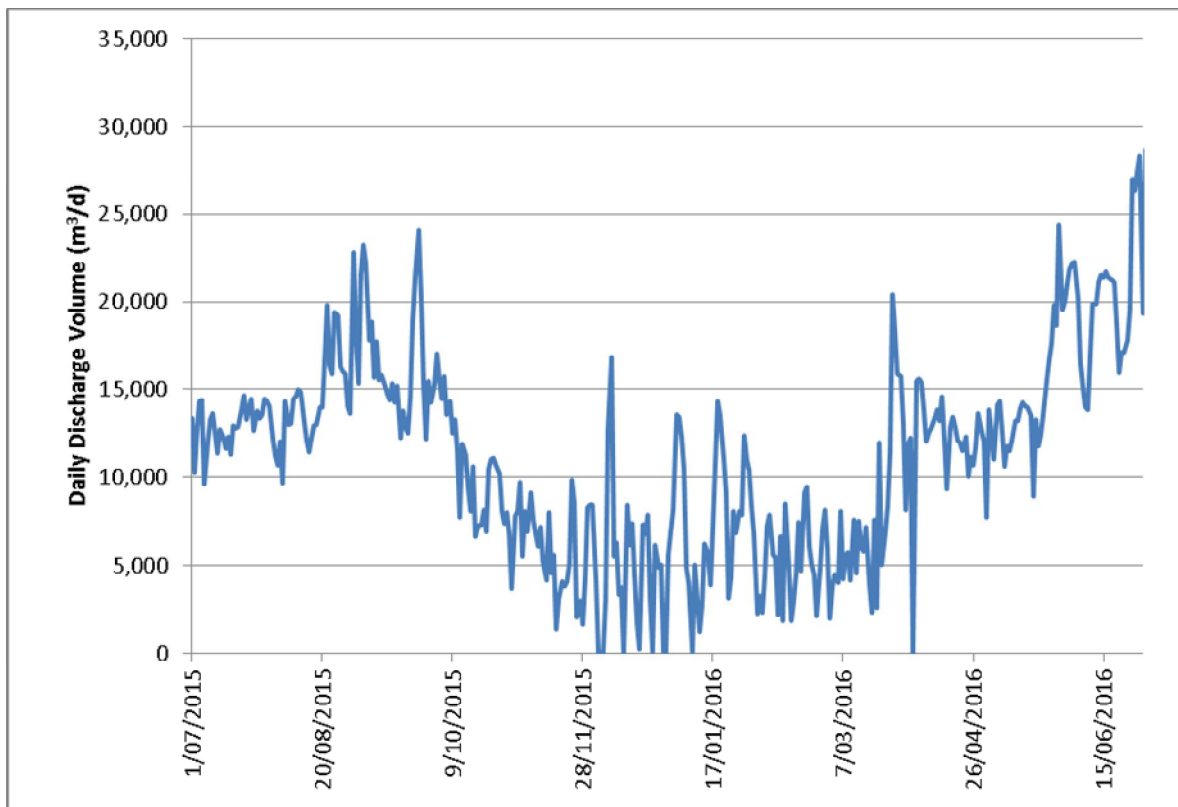

Figure 2-6: Daily discharge volume to Wairau Estuary

#### 2.5.4 Condition 56

*The Consent Holder shall install flow measuring devices after the outlet from wetland Pond 10 and Pond 6 (as shown on Plan Consent No C attached in Appendix 1 [see **Appendix B** for the Revised Plan Consent and **Appendix C** for the acceptance of this] to these conditions of consent) and record the daily volume of treated wastewater discharged to the Wairau Estuary. A copy of these records shall be made available to the Manager, Regulatory Department, Marlborough District Council, on request. A summary of this data shall be provided in the AMR required by Condition 7.*

A flow meter has been installed at the outlet from the wetlands, which is at Pond 14 (was numbered Pond 10 at the preliminary design stage). A flow meter has also been installed at the outlet to Pond 6 to record wastewater flow to irrigation areas.

#### 2.5.5 Condition 59

*The discharge of treated wastewater from the upgraded BSTP shall not cause any of the following effects outside the mixing zone described in Condition 58:*

- a) The natural temperature of the receiving water to change by more than 3 degrees Celsius;*
- b) Any conspicuous change in colour or clarity of the receiving water such that visual clarity of water is reduced by more than 50% as per the Water Quality Guidelines No 2 Ministry for the Environment (1994);*
- c) The concentration of dissolved oxygen of the receiving water to fall below 80 percent of the saturation content*

While the above effects have not been directly monitored in the receiving water, the results of wastewater monitoring (see Figures 2-7 to 2-10), indicate that there are unlikely to be any significant effects on water quality after reasonable mixing. Beca (2007) indicated that, based on computer modelling, the “worst case” initial dilution in the Estuary under existing average flows would be 50:1. In addition, the treated wastewater is only discharged under ebb tide conditions when there is a strong outflow from the Estuary. On this basis, none of the effects noted in Condition 59, are likely to have occurred after reasonable mixing, as a result of the discharge.

Successive surveys of the Estuary by Cawthron, in 2001, 2007, and 2016 (**Appendix E**), show that the outfall “*was having no discernible effect on sediment quality or the seabed dwelling community*”. A wastewater plume that remains submerged for some distance downstream of the outfall, strong tidal flows, sediment re-suspension and bed movement mitigate against any adverse effects occurring on the bed of the Estuary. The strong tidal flows results in significant re-oxygenation of the bed so that the potential for the creation of anoxic sediments is also very low.

The decommissioning of the Opawa River outfall and discharge of the combined wastewater to an area of rapid flushing in the Estuary, as well as the relatively high quality treated wastewater (including low concentrations of total and ammoniacal nitrogen), means that there is a very low likelihood of significant adverse effects occurring in the receiving water as a result of the discharge.

#### 2.5.6 Condition 61

*The Consent Holder shall take grab samples of treated wastewater at the outlet of Pond 10 following commissioning of the new wetland. Samples shall be analysed for the parameters and frequency shown in Table 1 (reproduced in Table 2-6 in this report). The results shall be reported in the AMP required by Condition 7.*

Condition 61 of the consent requires that grab samples be taken at the outlet of Pond 10 which was the final wetland pond number at the consent procurement (preliminary design) stage. However, following changes made during detailed design, Pond 14 now is the final wetland cell before discharge to the Estuary, and the grab samples are collected from the outlet of this pond. The results of sampling at the outlet of the wetland are shown in Figures 2-7 to 2-11.

Overall, the results shown in Figure 2-7 to 2-11, indicate good performance, particularly for reduction of Ammonia N and Faecal Coliform indicator bacteria. The TSS results for Pond 14 effluent are higher than expected and the cause is not obvious. A contributing factor could be the sludge accumulation in Pond 6 and possible carryover of sludge solids to Ponds 7 to 14. Further investigation is required.

Options to increase the treatment capacity of the industrial ponds are currently being investigated. These options include using the existing ponds but altering the treatment flow path. The goal of this study is to improve BOD and TSS removal as winery production increases. Removal of sludge from Pond 6 will also be investigated.

Metals and metalloids were not sampled during this monitoring period. It is recommended that annual testing for these parameters be carried out as required by Condition 61.

**Table 2-6: Wastewater Monitoring Requirements**

Parameter	Unit	Frequency of Analysis
Carbonaceous Biochemical Oxygen Demand (cBOD <sub>5</sub> )	g/m <sup>3</sup>	Monthly
Suspended Solids (SS)	g/m <sup>3</sup>	Monthly
Faecal Coliforms and Enterococci	cfu/100ml	Monthly
Ammoniacal Nitrogen (NH <sub>3</sub> -N)	g/m <sup>3</sup>	Monthly
Total Nitrogen (TN)	g/m <sup>3</sup>	Monthly
Dissolved Inorganic Nitrogen	g/m <sup>3</sup>	Monthly
Dissolved Reactive Phosphorus	g/m <sup>3</sup>	Monthly
Total Phosphorus (TP)	g/m <sup>3</sup>	Monthly
pH	pH units	Monthly
Temperature	Celsius	Monthly
Metals/metalloids: arsenic, cadmium, chromium, copper, lead, mercury, nickel, zinc	g/m <sup>3</sup>	Annually

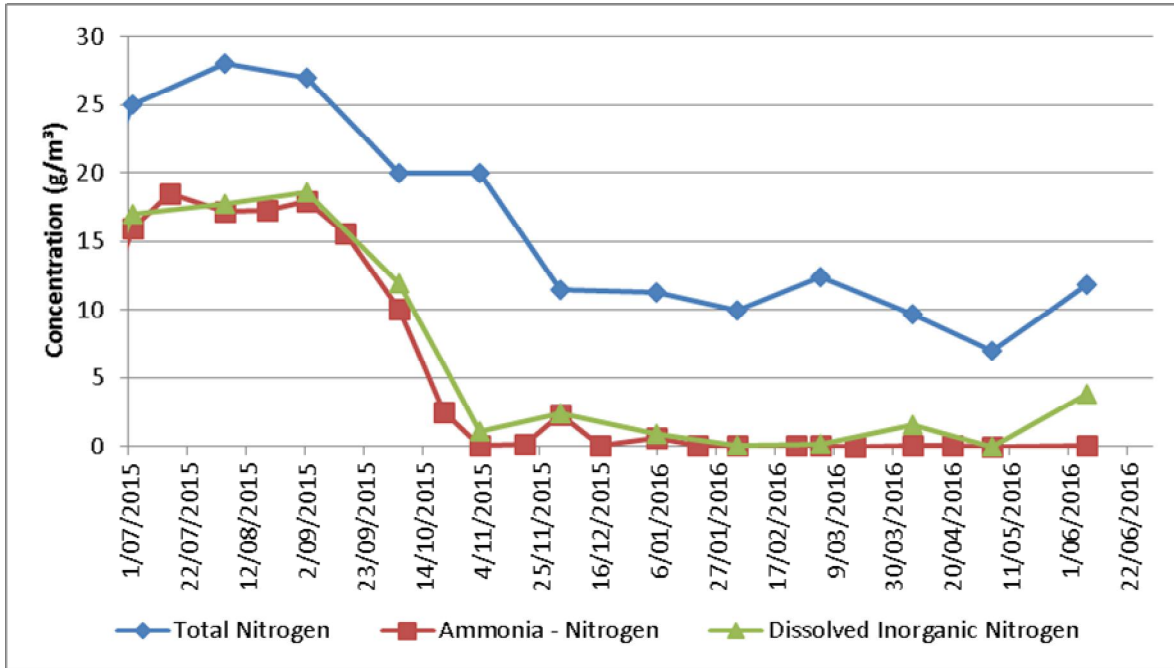

Figure 2-7: Wastewater monitoring results Pond 14 outlet – nitrogen species

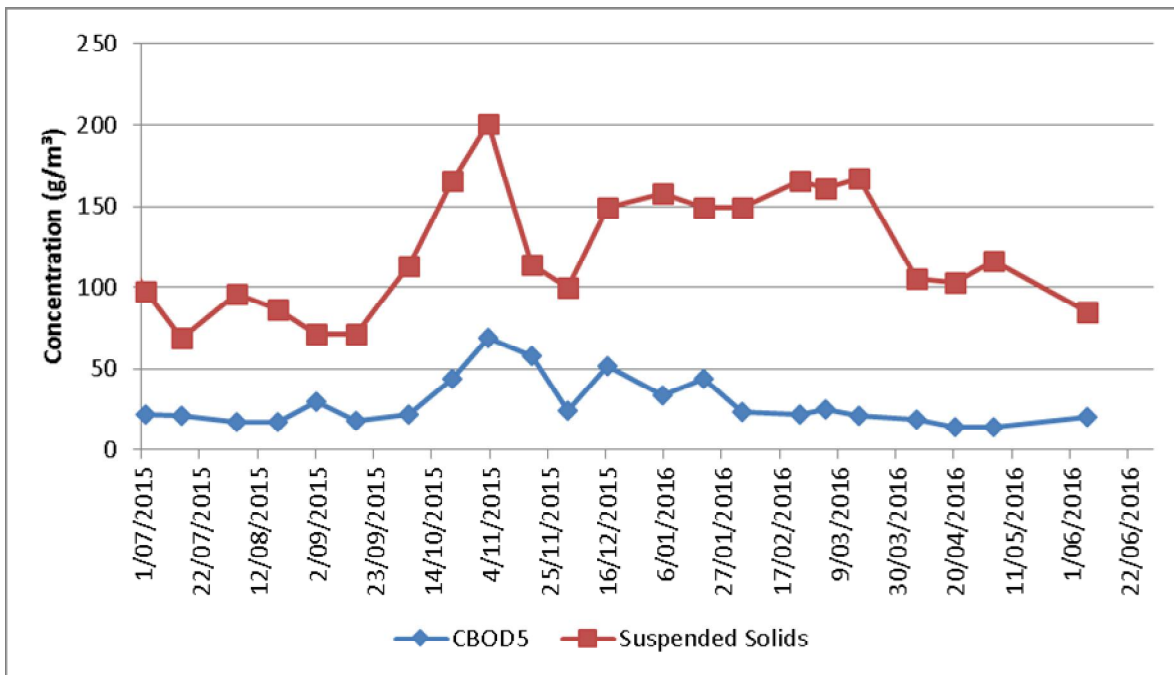

Figure 2-8: Wastewater monitoring results Pond 14 outlet – cBOD<sub>5</sub> and suspended solids

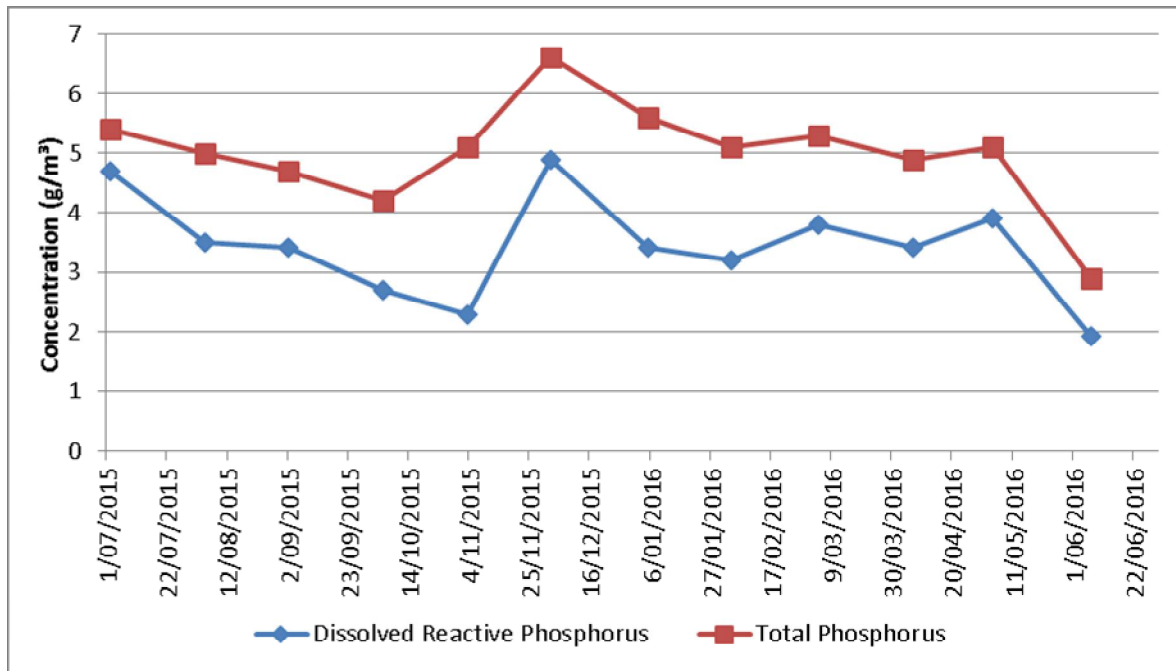

Figure 2-9: Wastewater monitoring results Pond 14 outlet – phosphorus species

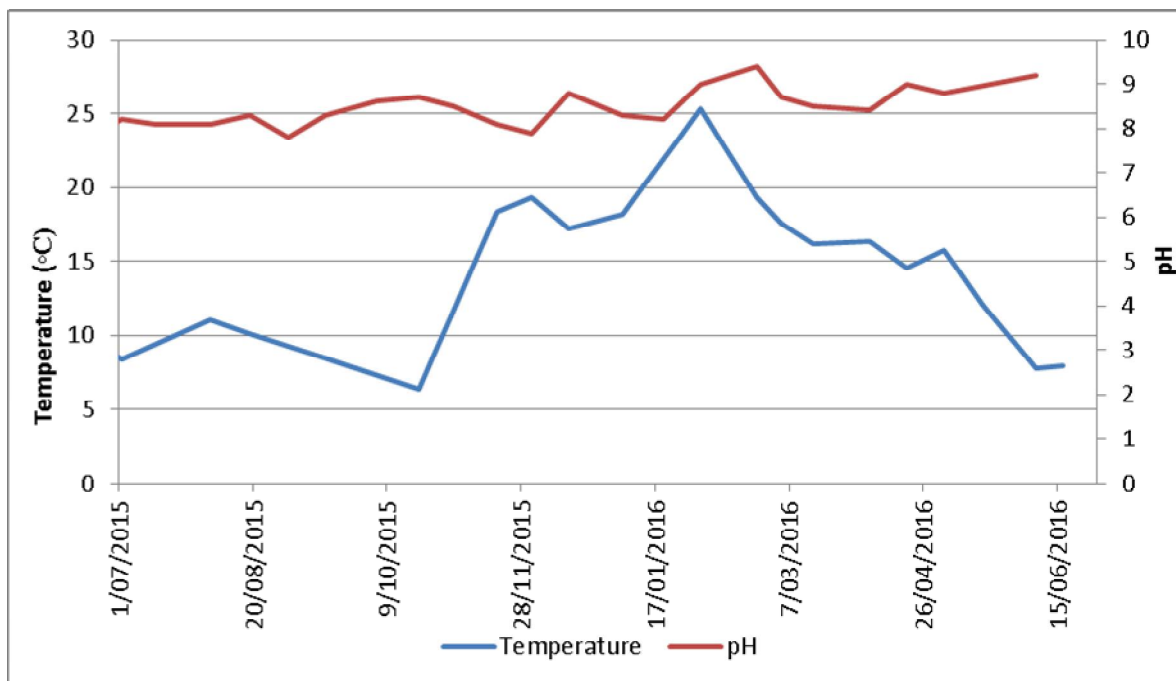
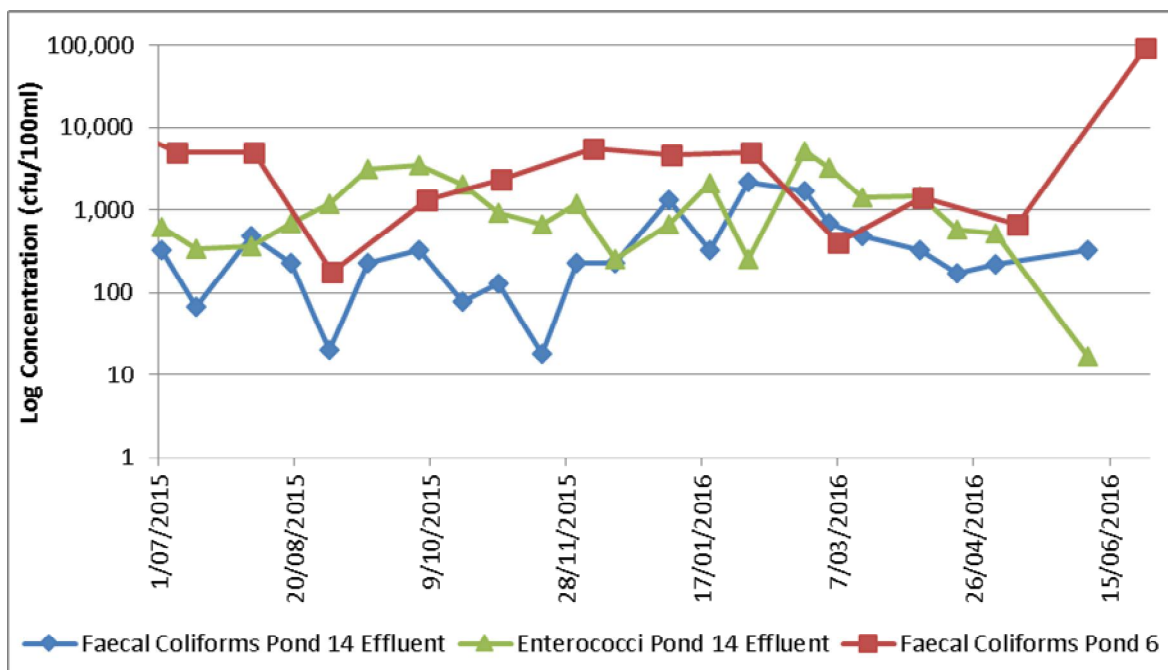

Figure 2-10: Wastewater monitoring results Pond 14 outlet – temperature and pH



**Figure 2-11: Wastewater monitoring results – Faecal coliforms at the outlet of Pond 6 and Faecal coliforms and Enterococci at Pond 14 on a Logarithmic Scale**

### 2.5.7 Condition 62 - Wastewater Monitoring Limits

The treated wastewater sampled under Condition 61 shall comply on an annual basis with the ammoniacal nitrogen and faecal coliform limits listed in Table 2 [reproduced in the Consent Limits columns of Table 2.7].

The monitoring results and consent limits for ammoniacal nitrogen and faecal coliform concentrations are given in Table 2.7. From Table 2.7, it can be seen that all results were well within consent limits.

Figure 2-11 shows the results of the wastewater faecal coliform and enterococci monitoring (after Pond 14), as well as results of faecal coliform monitoring at the outlet of Pond 6 (ie before the wetlands). Only one of the Pond 14 effluent faecal coliform samples was higher than the 90<sup>th</sup> percentile limit and so overall, this limit was not exceeded. Faecal coliform concentrations from samples at the outlet of Pond 6 (taken around the same time as the wastewater samples), were substantially higher than the wastewater values after Pond 14. These results show that Ponds 7 to 14 (ie wetlands), are effective in providing further disinfection of the wastewater before discharge to the Estuary. Pond 6 results do not have a consent compliance limit. One substantially higher measurement of 92,000 cfu/100ml was measured in Pond 6. It is likely that this sample included bird faecal matter and was therefore not representative of the entire pond.

**Table 2.7: Wastewater microbiological monitoring results and consent limits for Pond 14 Effluent**

Parameter	Units	Median		90 <sup>th</sup> Percentile	
		Consent Limits under existing flows	Results	Consent Limits under existing flows	Results
Ammoniacal Nitrogen (NH <sub>3</sub> -N)	g/m <sup>3</sup>	30	0.07	40	17
Faecal Coliforms	cfu/100ml	700	230	2,150	1,198

### 2.5.8 Conditions 63-70

*The Consent Holder shall carry out benthic surveys and water quality monitoring in the receiving environment to identify changes (notably adverse ecological impacts), as a result of the treated wastewater discharge. The survey design shall be consistent with the survey conducted by the Cawthron Institute (Technical Report on Effects of Outfall Discharge in Appendix D of Assessment of Environmental Effects for Upgrading of Blenheim Sewage Treatment Plant, September 2007).*

Condition 64 requires that benthic and water quality surveys commence in the Estuary, 2 years after commissioning of the new outfall (i.e. February 2016). This survey was carried out by Cawthron Institute during February to March 2016 and the report was issued 22 April 2016 (see **Appendix E**). Surveys are then required to be repeated at a further 2 year interval (i.e. February 2018), and thereafter at 5 yearly intervals, for the duration of the consent.

The 2016 survey results are summarised as follows:

- Some minor environmental and ecological differences were apparent between the 2006 and 2016 surveys.
- No overall adverse ecological effects of the BSTP discharge (and no breaches of the water quality consent conditions) were detected.
- These results are likely due to the quality of the discharge and its release only on the ebb tide, as well as the rapid tidal flushing that occurs within the vicinity of the outfall.



## **3 Summary**

### **3.1 Overview**

#### **3.1.1 Groundwater**

Groundwater testing was carried out at the required frequency (with the exception of one well (MSC-071) in June 2016. The results (with the exception of a high E. coli concentration in one of the wells in April 2016), were reasonably consistent over all the wells tested. The nitrogen load applied while irrigating remained below the monthly and yearly limits required by Condition 24. Potable water from wells p28w/4447 and p28w/4446 was tested monthly, and all results were <1 cfu/100ml.

#### **3.1.2 Pond dissolved oxygen**

DO concentrations in the treatment ponds met the consent limits. However, it is recommended that measurements are recorded between 11am and 2pm in the future.

#### **3.1.3 Treated wastewater**

Treated wastewater at the outlet of Pond 14 was monitored at the required frequency. Ammoniacal nitrogen and faecal coliform concentrations were well below the consent limits.

#### **3.1.4 Ecological effects**

The first post-upgrade benthic and water quality survey of the Estuary, required under the consent, was carried out during the 2015/16 reporting period. The study concluded that there were some minor environmental and ecological changes between the 2006 and 2016 surveys but overall, no adverse ecological effects were detected as a result of the BSTP discharge.

### **3.2 Compliance with Consent Conditions**

From an assessment of the results of monitoring in the period 1 July 2015 to 30 June 2016, all consent conditions were met with the exception of:

- Condition 30 – Groundwater levels were not measured at the required fortnightly intervals but all recorded levels during irrigation were compliant with greater than the 0.3 metre below ground surface requirement.
- Condition 44 - DO samples were not taken consistently on Wednesdays between 11am and 2pm.
- Condition 61 – Metals and metalloids were not sampled during this monitoring period.

It is recommended that as far as practicable, all sampling be carried out according to consent requirements.

Overall, the BSTP treatment ponds and wetlands appear to be performing well. While some minor improvements in the sampling regime are required, there is overall compliance with consent conditions.

Appendix A

**Consent U071181 including  
Site Plan and Monitoring  
Locations**

## **PART I: CONSENTS GRANTED**

### **1. Land Use Consents:**

A To disturb land, clear indigenous vegetation and excavate land for the purposes of constructing a wetland, an outfall pipeline, sludge ponds and drying beds.

B To use land for the purpose of disposing treated wastewater to land.

### **2. Discharge Permits:**

C To discharge treated wastewater to land.

D To discharge seepage from treatment ponds, wetlands, sludge ponds and drying beds.

E To discharge odour to air from treatment ponds, wetlands, sludge ponds and drying beds and from the land used for the disposal of treated wastewater.

F To discharge treated wastewater to the Opawa River.

### **3. Coastal Permit:**

G. Coastal Permit to:

a) use and maintain an existing outfall pipeline and a new outfall pipeline in the Coastal Marine Area of the Wairau Estuary

b) occupy space in the Coastal Marine Area of the Wairau Estuary with an existing outfall pipeline and a new outfall pipeline

c) discharge treated wastewater to the Wairau Estuary from a new outfall pipeline

## **PART II: GENERAL CONDITIONS**

1. The consents identified in Part I above are to be exercised in a manner which is consistent with the proposal and methodologies described in the documents, information and analysis provided by the Consent Holder in support of its Application for Resource Consents and held on Council file U071181.

2. Unless an alternative term is identified in the Specific Conditions, the resource consents granted have a term of 35 years from the date that the consents commence.

3. The Consent Holder shall, at least one month prior to the commencement of the works that are the subject of this consent, submit to the Manager, Regulatory Department, Marlborough District Council, final copies of the following draft management plans:

a) Blenheim Sewage Treatment Plant: Construction Management Plan - Wetlands, Sludge Ponds and Drying Beds, 5 July 2010, as amended by the evidence of H Archer dated 6 September 2010

b) Blenheim Sewage Treatment Plant: Construction Management Plan - Outfall and Outfall Pump Station, 5 July 2010, as amended by the evidence of H Archer dated 6 September 2010

c) Blenheim Sewage Treatment Plant: Buffer Planting Plan (undated)

d) Wastewater Irrigation Management Plan Blenheim Sewage Treatment Plant, version 3, 6 September 2010

e) Blenheim Sewage Treatment Plant: Operation and Management Plan, Revision C, July 2010

- f) **Blenheim Sewage Treatment Plant – Wetland Management Plan, 5 July 2010, as amended by the evidence of H Archer dated 6 September 2010**
4. **The final versions of the management plans listed in Condition 3 shall be prepared by qualified and experienced personnel with expertise in the matters that the individual management plans address. The management plans may be prepared as separate plans or as part of a combined plan.**
  5. **When preparing the final versions of the management plans listed in condition 3, the Consent Holder shall take into account any comments provided by the Manager, Regulatory Department, Marlborough District Council, on the draft management plans. No works may commence until the final management plans have been approved in writing by Council, through the Manager, Regulatory Department.**
  6. **All work shall be carried out in accordance with the approved final management plans, except that the Consent Holder may, at any time, submit to the Manager, Regulatory Department, Marlborough District Council, amendments to the plans for approval, provided those amendments improve the efficiency and/or quality of the construction works or operational activities, or avoid, remedy or mitigate an adverse effect.**
  7. **The Consent Holder shall provide to the Manager, Regulatory Department, Marlborough District Council, on or before 31 August in each year of the term of consent, from and including 2011, an Annual Monitoring Report (AMR) which must contain at least the following information:**
    - 7.1 **General**
      - a) **An analysis of the extent to which the Consent Holder has, in operating the BTSP and exercising these consents, complied with these Conditions of Consent and the extent and cause of any noncompliance, in each case with a summary of the environmental effects of the operation of the BTSP during the preceding 12 month period from 1 July – 30 June inclusive (the Reporting Period).**
      - b) **An identification and discussion of any operational difficulties, changes or improvements made to the wastewater treatment or operating processes, which would cause any material difference in environmental outcomes from the previous Reporting Period.**
      - c) **A comparison of results obtained over the Reporting Period with the results from previous reporting periods.**
      - d) **An identification of any maintenance works needed, proposed or undertaken to ensure compliance with these Conditions of Consent.**
      - e) **An identification of any improvements or changes required and the timetable for implementation.**
    - 7.2 **Discharge of Treated Wastewater to Land**
      - a) **The volume of treated wastewater applied to each of the Areas 1 – 3 (as shown at Plan Consent No A in Appendix 1 to these conditions of consent) in the Reporting Period.**
      - b) **A summary and analysis (including graphical and statistical representations) of all data collected as a requirement of the Specific Conditions applicable to the discharge consent to discharge treated wastewater to land.**

- c) A record and discussion of any complaints received regarding the discharge to land and the consent holder's response to those complaints.
- d) An analysis of any environmental effects, positive, neutral and adverse, which are attributable to the discharge of treated wastewater to land.

#### 7.3 Discharge of Odour

- a) Identification and discussion of any complaints received with respect to odour as per Condition 42 of the Discharge Permit to Air and any action taken to address the complaints.
- b) The measurements of Dissolved Oxygen (DO) concentrations as per Conditions 44 and 45 of the Discharge Permit to Air.
- c) An analysis of the data in terms of consent compliance and environmental effects.
- d) A discussion of any relevant operational changes or improvements carried out during the Reporting Period.
- e) A comparison of results in the Reporting Period to previous reporting periods and a discussion of any trends.
- f) Any complaints received in regard to the operation of the BSTP and the action(s) taken to address each complaint.

#### 7.4 Wastewater Monitoring and Benthic and Water Quality Monitoring

- a) A summary of all the monitoring data collected as a requirement of the conditions of the discharge permit to discharge treated wastewater to the Wairau Estuary during the Reporting Period.
- b) An analysis of the data in terms of consent compliance and environmental effects during the Reporting Period.
- c) A discussion of any relevant operational changes or improvements carried out during the Reporting Period.
- d) A comparison of results with previous years and a discussion of any trends during the Reporting Period.
- e) Any complaints received in regard to the operation of the BSTP and the action(s) taken to address each complaint.

#### 7.5 Outfall Pipelines

- a) A record of any maintenance works undertaken in accordance with Condition 52 of the Coastal Permit for the new and existing outfall pipelines.

8. With the agreement of the residents around the BSTP the Consent Holder shall set up a Community Liaison Group (CLG) which will consist of representatives of the community of residents affected by the BTSP who wish to participate and representatives of the Consent Holder. The CLG will meet every six months for the first two years following the commencement of these consents and, thereafter, at times to be agreed by the parties. The CLG's administration costs, including the taking and distribution of minutes, will be the responsibility of the Consent Holder.
9. All water and wastewater samples required to be taken under these Conditions of Consent shall be analysed in accordance with Standard Methods for the Examination of Water and Wastewater prepared and published by the American Public Health Association, the American Waterworks Association and the Water Environment Federation or any other suitable and comparable methodology approved by the Consent Authority.

10. Any laboratory carrying out analyses required under these Conditions of Consent shall be accredited for those analyses to NZS/ISO/IEC/17025 or equivalent, or to any other comparable standard approved by the Consent Authority.
11. The Consent Holder shall undertake a Performance Review of the BSTP five years after the commencement of the consents. The Performance Review shall include, but not be limited to:
  - a) compliance with consent conditions
  - b) analysis and conclusion of monitoring results
  - c) other available treatment technologies that may be options for the future
12. The Consent Holder shall undertake a Best Practice and further Performance Review of the BSTP ten years after the commencement of the consents. The Best Practice Review shall include, but not be limited to, research of available treatment technologies that would enable the removal of the discharge to the Wairau Estuary and improve the quality of the discharge.
13. The Consent Authority may review these Conditions of Consent by serving notice in September or October of any year for any of the following purposes:
  - a) To deal with any adverse effect on the environment which may arise from the exercise of these consents, which was not foreseen at the time of the granting of the consents.
  - b) To require the consent holder to adopt the best practicable option to remove or reduce any adverse effect on the environment.
  - c) To address any matters raised in the AMR required by General Condition 7.
  - d) To comply with the relevant requirements of a Council resource management plan.
  - e) To implement any outcomes of the Performance and Best Practice Reviews required under Conditions 11 and 12.
14. The Consent Holder shall be responsible for all costs associated with the monitoring of these resource consents and Conditions of Consent as required by Section 36 of the Resource Management Act 1991 and Marlborough District Council's Schedule of Fees.
15. The Consent Holder shall be responsible for all costs incurred by the Consent Authority associated with the review of or requested changes to any Management Plans which form part of this consent.
16. A copy of all resource consents granted under U071181, including conditions imposed, shall be readily available at Marlborough District Council's office building.

### **PART III: SPECIFIC CONDITIONS**

- A. Applicable to Land Use Consent to disturb land, clear indigenous vegetation and excavate land for the purposes of constructing a wetland, an outfall pipeline, sludge ponds and drying beds.**
17. This consent will have a term of three years from the date this consent commences.
18. The works the subject of this consent shall be undertaken in terms of Plan Consent No C in Appendix 1 to these conditions of consent.

19. The Consent Holder shall notify the Manager, Regulatory Department, Marlborough District Council, in writing of the proposed date of commencement of the construction works, at least 1 week prior to the start date of the works.

**B Applicable to Land Use Consent use land for the purpose of disposing of treated wastewater to land**

*Advisory Note: There are no special conditions for this land use consent.*

**C Applicable to Discharge Consent to discharge treated wastewater to land**

20. This consent will have a term of fifteen years from the date this consent commences.
21. The discharge shall only be of treated wastewater from the BTSP taken from the outlet of Pond 6, or from any point between Pond 6 and the outlet of Pond 10.
22. The discharge of wastewater to land shall be via drip irrigation or spray irrigation in the areas shown on Plan Consent No A. Only surface or subsurface drip irrigation shall be used within 25 metres of the site boundary and public walking tracks, except that on the western boundary adjoining neighbouring land, only surface or subsurface drip irrigation shall be used within 80 metres of the site boundary. For all other areas of the site, spray irrigation may be used.
23. The treated wastewater shall only be applied to the land using a deficit irrigation management regime. Deficit irrigation is defined as irrigation of a depth of wastewater that does not exceed the soil moisture deficit at the time of application. The soil moisture deficit shall be calculated in accordance with the Wastewater Irrigation Management Plan (IMP). The Consent Holder shall maintain records of rainfall and evapotranspiration that shall be made available to the Manager, Regulatory Department, Marlborough District Council, on request and which must be summarised in the AMR required by Condition 7.
24. The following net Nitrogen Loading Limits shall be observed:
- a) The maximum annual application of nitrogen shall not exceed a net loading of 200 kilograms of nitrogen per hectare per year.
  - b) Monthly applications shall not exceed a net loading of 50 kilograms of nitrogen per hectare.
  - c) Net loadings shall be calculated by taking into account the amounts of nitrogen contained in the pasture removed from the Irrigation Areas 1-3 of the site.
25. Spray irrigation shall not commence within 150 metres of adjacent property boundaries until the buffer planting required by the Buffer Planting Plan has grown to a height of at least 2 metres.
26. Spray irrigation of wastewater shall not occur within 10 metres of flowing surface water. Drip irrigation of wastewater shall not occur within 3 metres of flowing surface water.
27. Records shall be maintained of: the area of land used in each discharge event; the date, time and duration of the event; the wind speed and direction; and the wastewater application rate and dry matter quantities removed from specific areas and associated nitrogen content. A copy of these records shall be made available to

the Manager, Regulatory Department, Marlborough District Council, on request. A summary of this data shall be provided in the AMR required by Condition 7.

28. Groundwater shall be sampled monthly for a minimum of six months prior to commissioning of the irrigation system. Groundwater shall be sampled from the wells shown on Plan Consent No B in Appendix 1 to these conditions of consent. The samples shall be analysed for:

- a) Ammoniacal nitrogen.
- b) Nitrate nitrogen.
- c) Conductivity.
- d) *E-coli*.

The water level in each bore shall be measured and recorded at the time the sample is taken.

29. Groundwater shall be sampled monthly while irrigation is occurring in each area identified in Plan Consent No A in Appendix 1 to these conditions of consent, except that if irrigation has occurred for less than 14 days in the previous month no sampling is required. For each Irrigation Area, the wells identified within that area shown on Plan Consent No B attached in Appendix 1 to these conditions of consent, shall be sampled. The samples shall be analysed for:

- a) Ammoniacal nitrogen.
- b) Nitrate nitrogen.
- c) Conductivity.
- d) *E-coli*.

The water level in each bore shall be measured and recorded at the time the sample is taken.

30. The groundwater level in the wells shown on Plan Consent No B attached in Appendix 1 to these conditions of consent shall be monitored prior to wastewater irrigation commencing and at least fortnightly thereafter while irrigation is occurring. If the groundwater level measured in any monitoring well, for a particular irrigation area, is closer than 0.3 metres from the ground surface, irrigation shall cease in that area. Irrigation shall not recommence until the groundwater level is greater than 0.3 metres below the ground surface.

31. The potable water in well P28/4446 and one well on Lot 2 DP12207 shall be monitored as follows:

- a) A sample of water shall be taken from well P28/4446, within 30 days of wastewater irrigation commencing in Area 3 south of Hardings Road or Area 1 north of Hardings Road.
- b) A sample of water shall be taken from one potable supply well on Lot 2 DP12207, within 30 days of wastewater irrigation commencing in Area 1 north of Hardings Road.
- c) Sampling of both wells shall continue at monthly intervals during the wastewater irrigation season with a final sample being taken no later than 30 days after wastewater irrigation ceases each season.
- d) Sampling shall continue for a period of 5 years after wastewater irrigation commences. If *E.coli* are detected then the sampling shall continue for a further 5 years from that time.
- e) The samples shall be tested for *E.coli*. If *E.coli* are detected:



- (i) The Consent Holder shall immediately advise the well owner and the Manager, Regulatory Department, Marlborough District Council. A further sample shall be taken and tested for *E.coli* within 5 working days.
- (ii) The Consent Holder shall undertake an investigation into the likely causes of contamination and any measures recommended to avoid further contamination. Within 14 days of the first sample the Consent Holder shall provide a written report on the investigation to the well owner and the Manager, Regulatory Department, Marlborough District Council.

32 Prior to commencing the discharge;

- a) A weather station shall be installed at the office building shown on Plan Consent No B attached in Appendix 1 to these conditions of consent. The weather station shall measure and record windspeed and direction and rainfall and have sufficient instrumentation to allow the calculation of evapotranspiration. The wind speed and direction recorded at the weather station shall be deemed to represent the wind speed and direction for Irrigation Area 1.
- b) An anemometer and wind vane shall be installed at each of the two locations shown on Plan Consent No B attached in Appendix 1 to these conditions of consent. The anemometers and wind vanes shall measure and record wind speed and direction. The wind speed and direction recorded shall be deemed to represent the wind speed and direction for Irrigation Areas 2 and 3 respectively.
- c) The weather station, anemometers and wind vanes shall be maintained in an operational condition throughout the term of this consent.

33. Spray irrigation shall cease within 150 metres of the adjacent property boundaries as shown on Plan Consent No B attached in Appendix 1 to these conditions of consent for each Irrigation Area when the wind speed exceeds 15 kilometres per hour (as an average over 15 minutes) in the direction of the adjacent property boundaries as recorded at the respective weather recording device for that Irrigation Area. Drip irrigation may continue in such circumstances.

34. Treated wastewater shall only be applied to land at a rate such that ponding for a period greater than 12 hours does not occur.

35. The Consent Holder shall maintain a register of any complaints received relating to any aspect of the land discharge system. The record shall include the date and time of complaint, cause of the complaint, weather conditions at the time of complaint and action taken in response to the complaint. The register shall be made available to the Manager, Regulatory Department, Marlborough District Council, on request. A summary of complaints received by the consent holder shall be included in the AMR required by Condition 7.

36 For the duration of these consents, the Consent Holder shall install and maintain appropriate signage on any access points to the BSTP warning that partially treated wastewater is discharged to the land. Written confirmation of the signage wording, size and placement shall be provided to the Manager, Regulatory Department, Marlborough District Council, within three months of the commencement of this consent.

**D. Applicable to Discharge Consent to discharge seepage from treatment ponds, wetlands, sludge ponds and drying beds.**

37. The discharge the subject of this consent is limited to discharge from the base of the treatment ponds, the base of the wetlands and the base of the sludge ponds and drying beds.
38. The discharge shall only be exercised to the extent that it does not cause flooding or ponding on adjoining ground surfaces.

**E. Applicable to Discharge Consent to discharge odour to air from treatment ponds, wetlands, sludge ponds and drying beds and from the land used for the disposal of treated wastewater.**

39. The Consent Holder shall take all practicable steps to minimise the potential for generation of objectionable or offensive odour that causes an adverse effect at the legal boundary of any property adjoining the consent site.
40. For the purpose of monitoring compliance with Condition 39, an objectionable or offensive odour that causes an adverse effect is considered to have occurred if the Manager, Regulatory Department, Marlborough District Council, deems it so, applying the FIDOL (frequency, intensity, duration, offensiveness and location) criteria as set out in the Good Practice Guide for Assessing and Managing Odour in New Zealand (Ministry for Environment, 2003).
41. The Consent Holder shall respond as quickly as practicable to any complaints about odour and shall take all practicable measures to minimise the odour and prevent reoccurrence.
42. Any complaints received in regard to odour shall be recorded in a Complaints Register specifying the complaint, time and date, weather conditions and action required. A copy of the complaints shall be made available to the Manager, Regulatory Department, Marlborough District Council, on request. A summary of these complaints shall be part of the AMR required by Condition 7 of these Conditions of Consent.
43. Should an event occur which results in an objectionable or offensive odour at the boundary of any property, the Manager, Regulatory Department, Marlborough District Council, may request the Consent Holder to provide a written report within 15 days of the request being made, specifying:
- a) The cause or likely cause of the event and any factors which influenced its severity.
  - b) The nature and timing of any measures implemented by the consent holder to avoid, remedy or mitigate any adverse effects.
  - c) The steps to be taken, if any, in the future to prevent a recurrence of similar events.
44. The Consent Holder shall measure the Dissolved Oxygen (DO) concentrations in the wastewater near the outlet of Ponds 2A, 2B, 2C, 6 and 10 every Wednesday, except when a Wednesday falls on a public holiday, when the measurement shall be taken on the nearest following working day. The DO concentration shall be measured between 11am and 2pm and shall not be less than 2 grams of DO per cubic metre, on a rolling 10 percentile weekly measurement basis.

45. The DO of the wastewater in Ponds I1 and I2 shall be measured daily between 11am and 2pm during peak loading periods associated with the annual vintage, with DO concentrations maintained at not less than 0.5 grams per cubic metre on a 50 percentile basis. The time of the peak loading periods shall be determined by consultation between the Consent Holder and the Manager, Regulatory Department, Marlborough District Council. The results of the measurements shall be included in the AMR required by Condition 7.

**F. Applicable to Discharge Consent to discharge treated wastewater to the Opawa River.**

46. This consent shall have a term of three years from the date the consent commences.
47. The conditions of consent U961050.6 as shown in Appendix 2 to these conditions of consent will remain in force and will apply to this consent until the wetland is established and the new outfall pipeline is completed so that the Opawa outfall is able to be decommissioned.

**G. Applicable to Coastal Permit to:**

- a) use and maintain an existing outfall pipeline and a new outfall pipeline in the Coastal Marine Area of the Wairau Estuary
- b) occupy space in the Coastal Marine Area of the Wairau Estuary with an existing outfall pipeline and a new outfall pipeline
- c) discharge treated wastewater to the Wairau Estuary that has passed through a wetland (Pond 10)

*Advice Note: This coastal Permit does not authorise the discharge of wastewater from the existing outfall pipeline where that wastewater has not passed through the new wetland (Pond 10). That discharge is authorised under existing discharge consent U950167.1 which expires on 1 October 2011.*

48. This consent shall have a term of fifteen years from the date that it commences.
49. The outfall pipelines shall be located in general accordance with Plan Consent No C attached in Appendix 1 to these conditions of consent with the outlets at about NZMG E 2,598,349 NZMG N 5,966,313.
50. The outfall pipelines shall be maintained in an operational condition at all times.
51. The Consent Holder shall undertake annual external visual inspections of the outfall pipeline structures for the duration of the consent. A report shall be submitted to the Manager, Regulatory Department, Marlborough District Council, within 20 working days of the inspection being carried out. The report shall include but not be limited to:
- a) The date and time of the inspection.
  - b) The condition of the outfall structures.
  - c) Any maintenance work that may be required, and if it is required, when the work will be carried out.
52. Should the report required by Condition 51 identify the requirement for maintenance, confirmation of the completion of the works shall be forwarded to the Manager, Regulatory Department, Marlborough District Council, within twenty working days of the completion of the works.

53. The outfall pipelines shall not interfere with any public right of navigation.
54. The existing buoy marking the location of the end of the existing outfall shall be marked with the words *Sewer Outfall* and the lettering used shall be bold and clear such that it can easily be read from a distance of 10 metres.
55. The total discharge of treated wastewater authorised by this consent shall not exceed an average daily volume of 28,500 cubic metres, where the average volume is calculated on a continuous basis over a period of 365 consecutive days. The maximum discharge volume per day shall not exceed 103,680 cubic metres.
56. The Consent Holder shall install flow measuring devices after the outlet from wetland Pond 10 and Pond 6 (as shown on Plan Consent No C attached in Appendix 1 to these conditions of consent) and record the daily volume of treated wastewater discharged to the Wairau Estuary. A copy of these records shall be made available to the Manager, Regulatory Department, Marlborough District Council, on request. A summary of this data shall be provided in the AMR required by Condition 7.
57. The discharge of treated wastewater shall generally take place over a four hour period, commencing one hour after high tide, except that longer discharge periods may be used after a prolonged wet weather event when peak wastewater flows and/or high rainfall cause the storage capacity of the ponds/wetland to be exceeded.
58. The proposed mixing zone for the discharge to the Wairau Estuary shall be as shown on Plan No D in Appendix 1 to these conditions of consent.
59. The discharge of treated wastewater from the upgraded BSTP shall not cause any of the following effects outside the mixing zone described in Condition 58 above:
  - a) The natural temperature of the receiving water to change by more than 3 degrees Celsius;
  - b) Any conspicuous change in colour or clarity of the receiving water such that visual clarity of water is reduced by more than 50% as per the Water Quality Guidelines No 2 Ministry for the Environment (1994);
  - c) The concentration of dissolved oxygen of the receiving water to fall below 80 percent of the saturation content.
60. There shall be no undesirable biological growths as a result of the discharge.

#### **Wastewater Monitoring**

61. The Consent Holder shall take grab samples of treated wastewater at the outlet of Pond 10 following commissioning of the new wetland. Samples shall be analysed for the parameters and frequency shown in Table 1. The results shall be reported in the AMP required by Condition 7.
62. The treated wastewater sampled under Condition 61 shall comply on an annual basis with the ammonical nitrogen and faecal coliform limits listed in Table 2.

**Table 1: Monitoring Parameters**

Parameter	Unit	Frequency of Analysis
Carbonaceous Biochemical Oxygen Demand (CBOD <sub>5</sub> )	g/m <sup>3</sup>	Monthly
Suspended Solids (SS)	g/m <sup>3</sup>	Monthly
Faecal Coliforms and Enterococci	cfu/100ml	Monthly
Ammoniacal Nitrogen (NH <sub>3</sub> -N)	g/m <sup>3</sup>	Monthly
Total Nitrogen (TN)	g/m <sup>3</sup>	Monthly
Dissolved Inorganic Nitrogen (DIN)	g/m <sup>3</sup>	Monthly
Dissolved Reactive Phosphorus (DRP)	g/m <sup>3</sup>	Monthly
Total Phosphorus (TP)	g/m <sup>3</sup>	Monthly
pH	pH units	Monthly
Temperature	°Celsius	Monthly
Metals/metalloids: arsenic, cadmium, chromium, copper, lead, mercury, nickel, zinc	g/m <sup>3</sup>	Annually

**Table 2: Wastewater Limits**

Parameter	Unit	Median		90 Percentile	
		Estimated Existing Flow	Future Design Flow	Estimated Existing Flow	Future Design Flow
Ammoniacal Nitrogen (NH <sub>3</sub> -N)	g/m <sup>3</sup>	30	15	40	20
Faecal coliforms	cfu/100 ml	700	350	2150	1075

**Advice Note:** The future design flows are an average daily volume of 28,500 cubic metres and to meet the limits the initial dilution has been calculated as 25:1. When lower flows are being discharged, the wastewater concentration limits can be increased after discharge based on a back calculation from the assessed initial dilution. The Cawthron Institute (Technical Report on Effects of Outfall Discharge in Appendix D of Assessment of Effects for Upgrading of Blenheim Sewage Treatment Plant, September 2007) has determined that an initial dilution of 50:1 can be achieved at an average daily volume of 14,250 cubic metres (estimated existing flow).

**Table 3: Benthic Survey Parameters**

Station Code	Station Location		NMG N (m)	Replicates per Station		
	NZMG E (m)			Infauna	Sediment Chemistry	Shellfish
OF P	2,598,336		5,966,320	3	4	1 <sup>a</sup>
25DS P	2,598,350		5,966,340	3	4	1
50DS P	2,598,357		5,966,361	3	4	1
100DS P	2,598,404		5,966,466	3	4	1
200DS P	2,598,476		5,966,466	3	4	1
300DS P	2,598,539		5,966,546	3	4	1
OF O	2,598,326		5,966,314	3	4	1 <sup>a</sup>
25DS O	2,598,353		5,966,301	3	4	1
50DS O	2,598,335		5,966,368	3	4	1
100DS O	2,598,361		5,966,417	3	4	1
200DS O	2,598,434		5,966,500	3	4	1
300DS O	2,598,496		5,966,582	3	4	1 <sup>a</sup>

**Key:**

- OF Outfall
- DS Downstream
- P Plume
- O Outside (of the plume)

a No target species of shellfish found at this station during 2006 survey

## **| Receiving Environment Monitoring**

63. The Consent Holder shall carry out benthic surveys and water quality monitoring in the receiving environment to identify changes (notably adverse ecological impacts), as a result of the treated wastewater discharge. The survey design shall be consistent with the survey conducted by the Cawthron Institute (Technical Report on Effects of Outfall Discharge in Appendix D of Assessment of Environmental Effects for Upgrading of Blenheim Sewerage Treatment Plant, September 2007).

### **Benthic Survey**

64. A benthic survey shall be carried out in accordance with the station designation, locations, and replication as set out in Table 3:
- a) Within two years of commissioning the new outfall pipeline, but not less than 12 months after commissioning.
  - b) Within four years of commissioning the new outfall pipeline, but not less than three years after commissioning.
  - c) Thereafter at five yearly intervals.
65. Twelve stations (six pairs, located both inside and outside the wastewater plume) shall be sampled at discreet distances (i.e. <5m, 25m, 50m, 100m, 200m and 300m) downstream from the discharge.
- a) Infauna shall be collected via 13 cm diameter cores (approx 10 cm depth) and samples shall be processed using a 0.5 mm sieve with taxa collected counted and identified to the lowest practicable taxonomic level.
  - b) Sediment samples shall be collected via 6 cm (minimum) diameter cores manually driven into the benthic sediments to a depth of 10-15 cm. The colour and the visible presence/absence of any anoxic patches or layers within the cores shall be recorded. One of the four replicate cores per station shall be split and photographed to provide a permanent visual record. The top 5 cm of the remaining three cores shall be sub-sampled for analysis of the following:
    - i) Sediment texture – particle grain size distribution
    - ii) Organic content (total organic carbon or ash-free dry weight)
    - iii) Metals/Metalloids – arsenic (As), cadmium (Cd), chromium (Cr), copper (Cu), mercury (Hg), nickel (Ni), lead (Pb), and zinc (Zn)
66. Where present, 15-20 shellfish of the target species *Paphies austral* (pipi) shall be collected and composite tissue samples analysed for faecal coliforms and trace metals/metalloids (As, Cd, Cr, Cu, Hg, Pb, Ni, Zn).

### **Water Quality**

67. At the same time as the seabed surveys, near surface (within 1m) and near-bottom (within 1m) water quality samples shall be taken at the following sites during the ebb tide discharge: 300-550 metres upstream of the discharge; at the downstream edge of the mixing zone (300 metres downstream of the discharge) and at the bar entrance (500-600 metres downstream).
68. The water quality at each site shall be visually assessed for:
- a) Scums, foams and other floatable material
  - b) Conspicuous changes in colour or clarity

69. Water quality samples shall be taken and tested for the following:
- a) Presence of any objectionable odour
  - b) Biochemical oxygen demand (BOD), total suspended solids (TSS), faecal coliforms, Enterococci, and trace metals/metalloids (As, Cd, Cr, Cu, Hg, Pb, Ni, Zn).
  - c) Nutrients (Total-N, Ammonical-N, Dissolved reactive phosphorus)
  - d) Standard hydrological parameters (pH, temperature, dissolved oxygen, salinity and turbidity)
70. The Consent Holder shall forward a record of the outcomes of Conditions 63 to 69 to the Manager, Regulatory Department, Marlborough District Council, within one month of the analysis of the monitoring being completed.

#### **Iwi Liaison**

71. The Consent Holder shall make a senior Marlborough District Council representative available to meet with Ngati Toa, Ngati Rarua and Rangitane at six monthly intervals throughout the duration of the consent, to review treatment plant performance, including the results of any monitoring.

#### **Changes/Modifications**

72. Any changes in the scope, frequency or timing of the monitoring programme identified as being necessary by the Consent Authority shall be addressed in the course of any review of conditions initiated by the Consent Authority under Section 128 of the RMA, as contemplated by Condition 13.



**Appendix 1**

**Plan Consent No A**  
**Plan Consent No B**  
**Plan Consent No C**  
**Plan Consent No D**



**Legend**

- Proposed Buffer Planting
- Existing Buffer Planting
- 150 m to MDC Boundaries
- Track Walkway DCC
- Track Walkway MDC
- Proposed Sewer Cutfall
- Irrigation Areas
- Spray Irrigation
- Proposed Designation
- Onp Irrigation
- Spray Irrigation to cease if average wind speed > 15 km/hr in direction of adjacent boundary

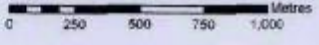

PLAN CONSENT NO A

File Name: B:\Easw\GIS\100\GIS\HDC\11200\Project\GIS\11200\plancon 2014.rvt



0 250 500 750 1,000 Metres

PLAN CONSENT NO B

PLAN CONSENT NO. C

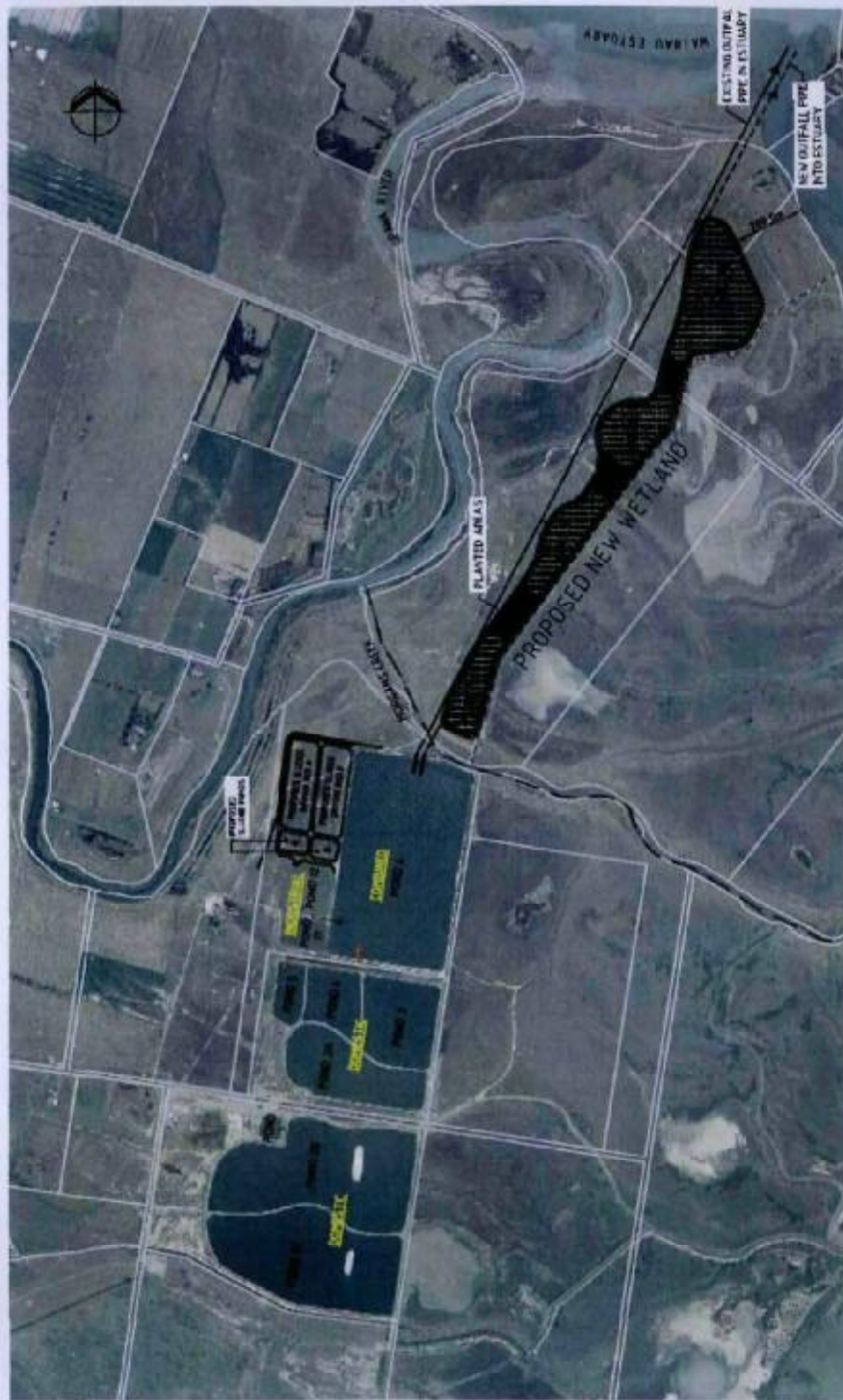

**RESOURCES CONSERVATION**  
NOT FOR CONSTRUCTION

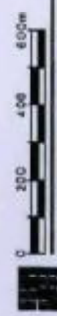

6413042  
6413042-C-62

BLENHHEIM SEWAGE TREATMENT PLANT  
UPGRADING CONCEPT PLAN

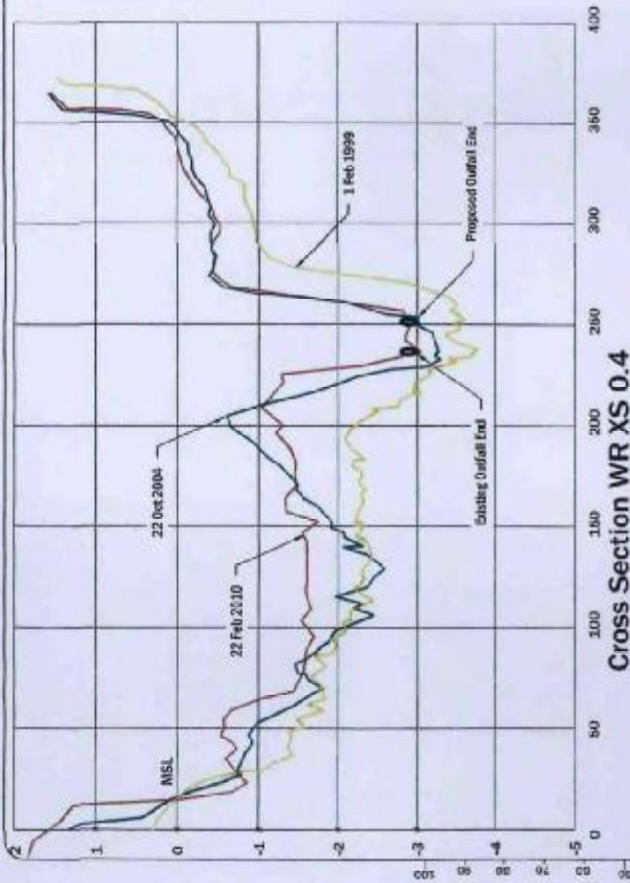

Plan : Cross Section WR XS 0.4 Scale 1:2000

MARLBOROUGH DISTRICT COUNCIL  
 SERVICE SQUARE, P.O. BOX 443  
 BLENHEIM 7540, NEW ZEALAND  
 TEL: (03) 535-7165, FAX: (03) 535-1166

Blenheim Sewerage  
 3STP  
 Wai'ou Estuary Outfall and Cross Section

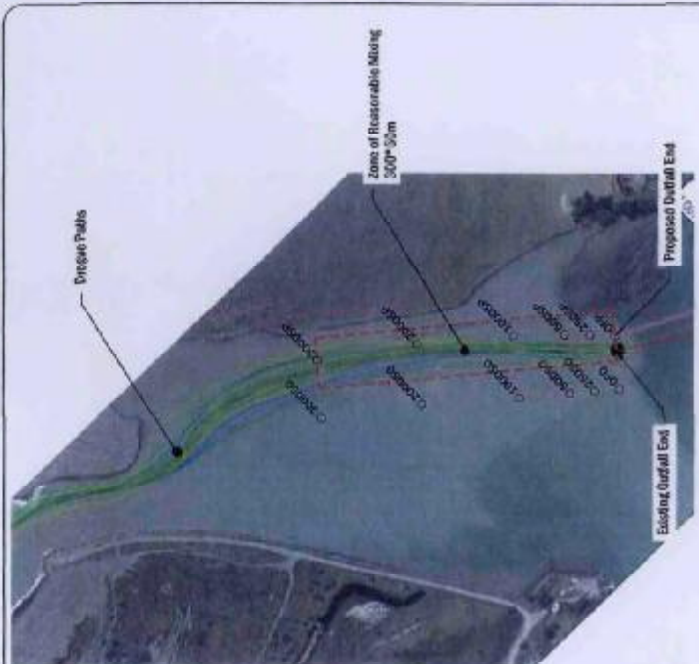

Plan : Zone of Reasonable Mixing  
 Scale 1:40000

Station Code	NZMG E	NZMG N
OFF	2,093,849	5,966,513
25D SP	2,593,367	5,966,931
50D SP	2,693,384	5,966,949
100D SP	2,593,416	5,966,386
200D SP	2,593,460	5,966,462
300D SP	2,593,636	5,966,546
OFC	2,658,806	5,866,945
250 SO	2,658,324	5,966,365
500 SO	2,658,393	5,966,385
1000 SO	2,658,370	5,966,424
2000 SO	2,658,434	5,966,500
3000 SO	2,658,498	5,966,582

DATE	BY	CHKD	APP'D	REV	DESCRIPTION
2/5/04					

Appendix B

**Amended Consent Drawings  
and Condition 32(b) of  
U071181 prepared by CH2M  
Beca**

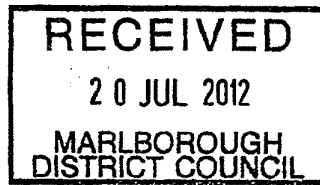

PO Box 13960, Christchurch, New Zealand  
T: +64 3 366 3521 // F: +64 3 366 3188  
E: info@beca.com // www.ch2mbeqa.co.nz

Marlborough District Council  
PO Box 443  
Blenheim 7240

11 June 2012

Attention: Guy Boddington

Dear Guy

**Blenheim Sewage Treatment Plant Upgrade-Amended Consent Drawings and Condition 32 (b) of U071181**

At a meeting between yourself, Paul Whyte and Graeme Jenner (Beca) on 5<sup>th</sup> April 2012, the status of additional activities, in respect of the upgrading of the Blenheim Sewage Treatment Plant (BSTP), was agreed. In a subsequent letter to (MDC) dated 10<sup>th</sup> May 2012, it was noted that Beca would send amended Consent Plans Nos A and B to MDC, together with an amendment to Conditions 32 (a) and (b) of Consent U071181.

Consent Plans Nos A and B have now been updated and are included as Attachment A.

The proposed amended consent conditions (amendments in bold) are:

**Condition 32(a)**

*A weather station shall be installed at the office building shown on Plan Consent No B attached in Appendix 1 to these conditions of consent. The weather station shall measure and record wind speed and direction and rainfall and have sufficient instrumentation to allow calculation of evapotranspiration. The wind speed and direction recorded at the weather station shall be deemed to represent the wind speed and direction for Areas 1 **and 2**.*

**Condition 32 (b)**

*"An anemometer and wind vane shall be installed at the location **shown as Wind Measurement Site (Area 3)** on Plan Consent No B attached in Appendix 1 to these conditions of consent. The anemometer and wind vane shall measure and record wind speed and direction. The wind speed and direction recorded shall be deemed to represent the wind speed and direction for **Irrigation Area 3**".*

Please contact the undersigned to acknowledge receipt of the following:

- Letter to MDC dated 10<sup>th</sup> May 2012 with agreed status of additional activities
- This letter with amended consent drawings and proposed amendments to Condition 32 (a) and (b) of U071181



Yours faithfully  
**Graeme Jenner**  
Associate - Environmental

A handwritten signature in black ink, appearing to read "GJ".

on behalf of  
**CH2M Beca Ltd**  
Direct Dial: +64 3 374 3156  
Email: [graeme.jenner@beca.com](mailto:graeme.jenner@beca.com)

**Copy**  
Stuart Donaldson: Marlborough District Council

Att.





**CH2M BECA**

Page 3  
11 June 2012

**Attachment A: Plan Consent Nos A and B**

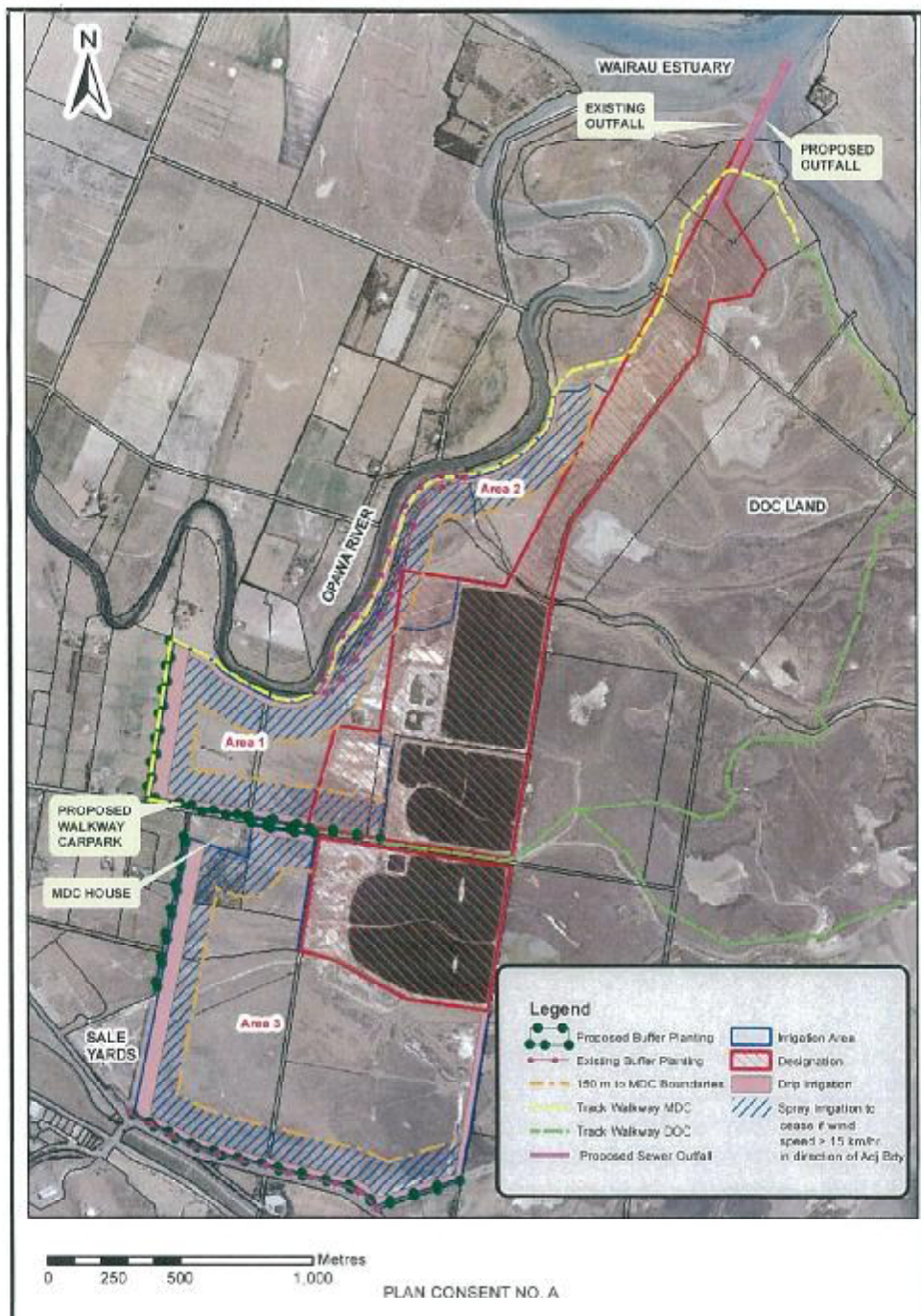

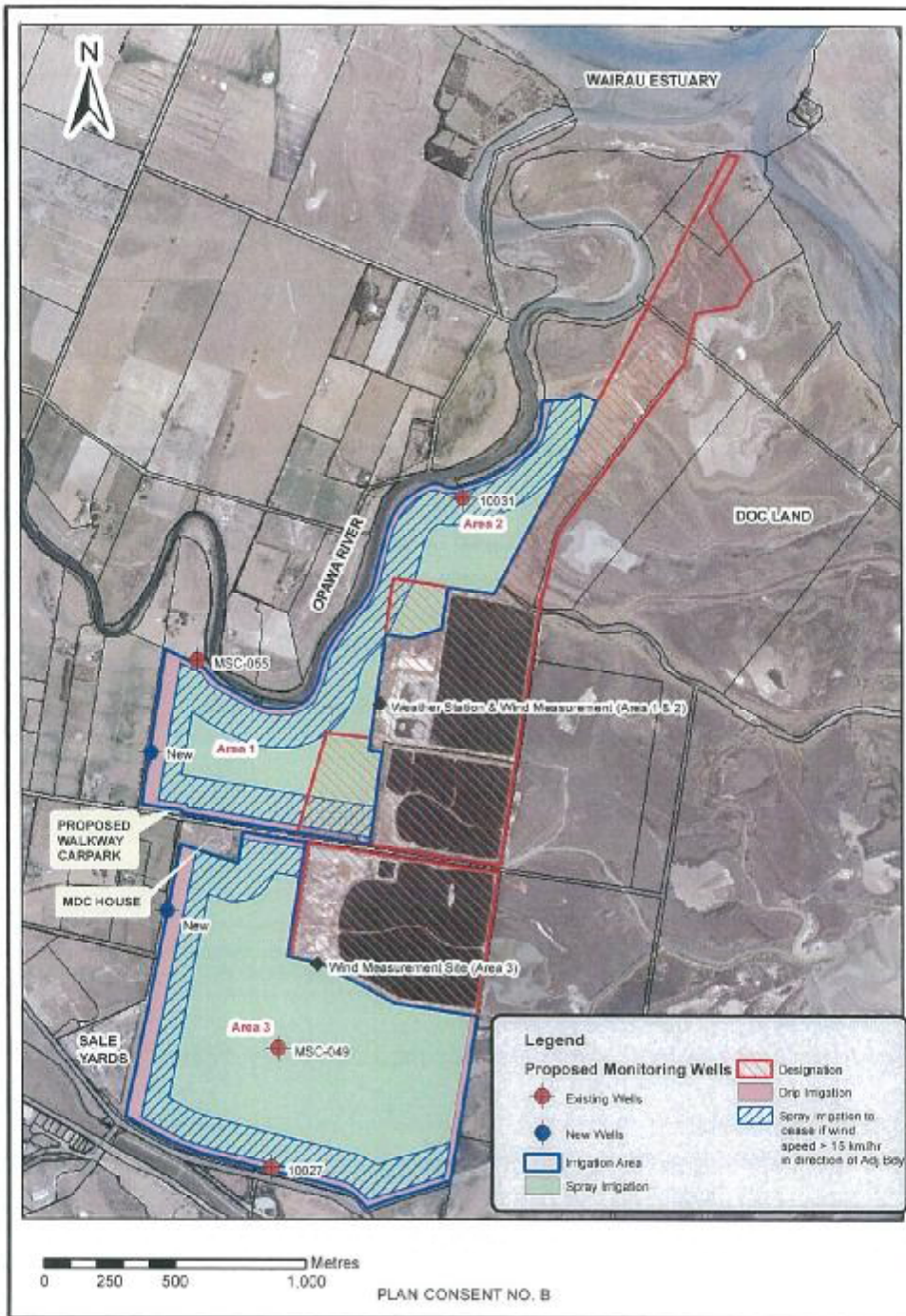

**Legend**

- |                                                                                                                                                                           |                                                                                                                                                                               |
|---------------------------------------------------------------------------------------------------------------------------------------------------------------------------|-------------------------------------------------------------------------------------------------------------------------------------------------------------------------------|
| <ul style="list-style-type: none"> <li>Proposed Monitoring Wells</li> <li>Existing Wells</li> <li>New Wells</li> <li>Irrigation Area</li> <li>Spray Irrigation</li> </ul> | <ul style="list-style-type: none"> <li>Designation</li> <li>Onp Irrigation</li> <li>Spray irrigation to cease if wind speed &gt; 15 km/hr in direction of Adj. Bay</li> </ul> |
|---------------------------------------------------------------------------------------------------------------------------------------------------------------------------|-------------------------------------------------------------------------------------------------------------------------------------------------------------------------------|

0 250 500 1,000 Metres

PLAN CONSENT NO. B

Appendix C

**Amended Consent Drawings  
and Minor Amendments to  
Condition 32 prepared by  
MDC**

MARLBOROUGH DISTRICT COUNCIL  
PO BOX 443  
BLENHEIM 7240  
NEW ZEALAND

TELEPHONE (0064) 3 520 7400  
FACSIMILE (0064) 3 520 7488  
EMAIL [mdc@marlborough.govt.nz](mailto:mdc@marlborough.govt.nz)  
WEB [www.marlborough.govt.nz](http://www.marlborough.govt.nz)



25 July 2012

Record No: 12245650  
File Ref: U071181  
Ask For: Guy Boddington

Mr Graeme Jenner  
CH2M Beca Ltd.  
PO Box 13960  
Christchurch

Dear Graeme

### **BSTP Upgrade - Amended Consent Drawings and Minor Amendments to Condition 32**

I refer to your letters of 10 May 2012 and 11 June 2012, addressed for my attention. The letter of 10 May 2012 summarised our discussion of 5 April 2012 which covered the installation of various infrastructure in and around the stopbank and Orua Canal crossing, drain filling and slotted pipe installation in irrigation areas, the use of herbicides in the new wetland and crossing under the Riverlands Industrial Drain by an irrigation mainline.

The Regulatory Department is in agreement with the reasons stated in para 2 of the 10 May letter that these activities are permitted in terms of various conditions of consent U071181, the new Designation and an existing Resource Consent for aquatic herbicide application held by MDC (U070702).

On 5 April we also discussed required amendments to Plan Consent Nos A and B and condition 32 (brought about by a reduction in the irrigation areas), without the requirement of having to apply for a s127 variation. The rationale for this was that the changes would result in *improvements in the efficiency of the operation* (and thus falls within the ambit of Part II General Condition 6 of Resource Consent U071181). Council's Regulatory Department supports this view.

I trust that this response is suffice for your records - please call me if you have any queries.

Yours sincerely

GUY BODDINGTON  
RESOURCE MANAGEMENT OFFICER

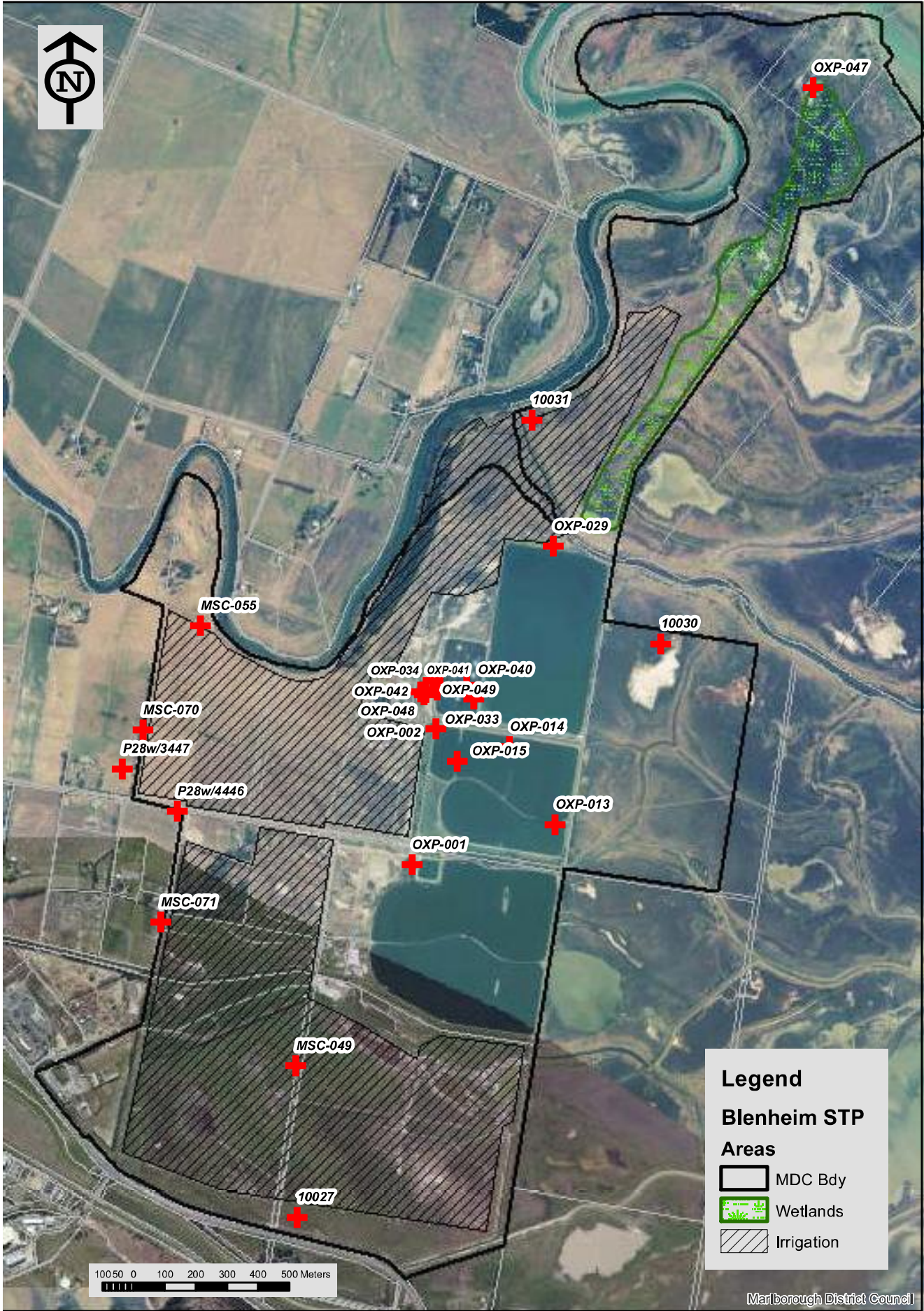

**Legend**

**Blenheim STP Areas**

- MDC Bdy
- Wetlands
- Irrigation

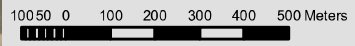

Appendix D

## Annual Inspection of the MDC Wairau Bar Effluent Pipeline



**SEWER  
OUTFALL**





**BSTP**  
TREATED EFFLUENT  
DISCHARGE

MARLBOROUGH  
DISTRICT COUNCIL  
Phone 520 7400



**BSTR**  
TREATED EFFLUENT  
DISCHARGE  
MARIPOSA  
Phone: 520-740-1111





**N-Viro**<sup>®</sup>  
MOORING SYSTEMS



12 Kent Street

PICTON 7220

New Zealand

---

Phone: 03 573 8045  
Fax: 03 573 8991

Website: [www.n-viro.com](http://www.n-viro.com)  
Email: [donna@nviro.com](mailto:donna@nviro.com)

---

Marlborough District Council  
P O Box 443  
Blenheim 7240

Order No: WO-034421Rad2

26<sup>th</sup> February 2016

## Annual Inspection of the NEW Wairau Bar Effluent Pipeline

As per request from Rob Addis:

- **Pipeline condition:**  
Good condition with 1 metre exposed, no scouring under the exposed pipe- no photos, visibility NIL
- **Anode condition 2x:**  
10% wasted
- **Buoy condition:**  
Good condition – see photos via separate e-mail
- **Small chain condition:**  
Good condition from the buoy to the riverbed, diver could not find the end of the chain even though they dug for it
- **Shackle condition:**  
The buoy shackles are in good condition - could not locate the other end of the pipeline as it is buried in the riverbed
- **Visibility**  
Nil – The Diver's did all work by feel

Regards

Donna & Mike Baker  
Managing Directors



Marlborough District Council  
P O Box 443  
Blenheim 7240

Order No: WO-034421Rad2

26<sup>th</sup> February 2016

## Annual Inspection of the OLD Wairau Bar Effluent Pipeline

As per request from Rob Addis:

- **Marker buoy condition:**  
Buoy okay, signage average (some paint missing)- see photos in separate e-mail
- **Marker buoy anode condition:**  
Completely wasted; needs replacing
- **Signage condition:**  
Average – see photos via separate e-mail
- **Coating & Chain condition:**  
The chain and shackles that were visible are in good condition. The chain section that attaches to the pipeline was not visible for inspection
- **Discharge Nozzle condition:**  
This was buried below the river silt, not visible to inspect
- **Riverbed condition surrounding the nozzle:**  
Riverbed shows no sign of change from last survey, compacted hard black sand
- **Pipe condition:**  
Not visible to inspect
- **Establish length of pipe not covered by riverbed material:**  
Zero
- **Material entangled around the pipe support:**  
Nil

Regards

Donna & Mike Baker  
Managing Directors

Appendix E

## Benthic Survey

Appendix E

## Benthic Survey



REPORT NO. 2827

**BLenheim SEWAGE TREATMENT PLANT  
RECEIVING ENVIRONMENT MONITORING 2016**

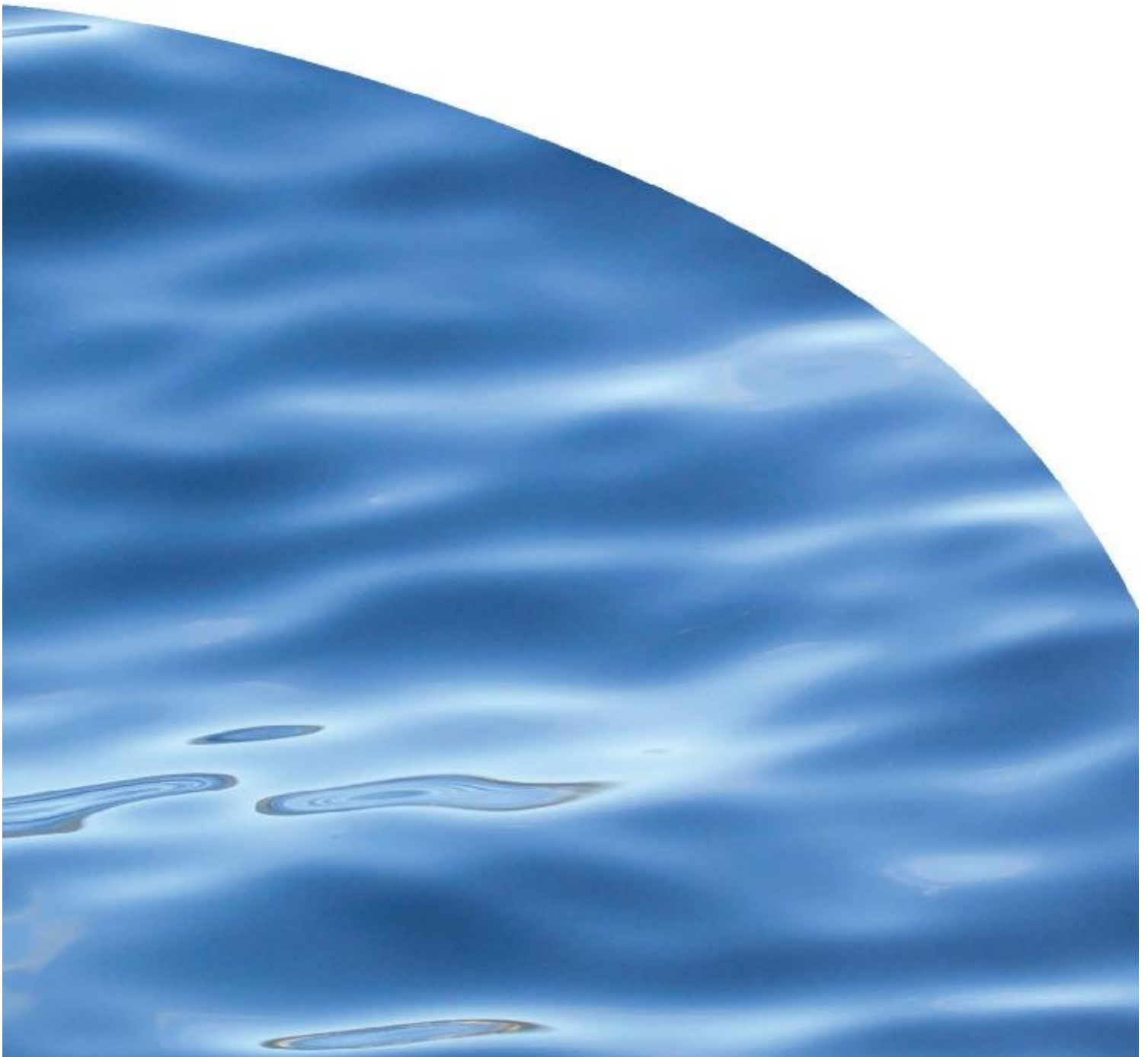





# BLENHEIM SEWAGE TREATMENT PLANT RECEIVING ENVIRONMENT MONITORING 2016 2016

ANNA BERTHELSEN, DON MORRISEY

Prepared for Marlborough District Council

CAWTHRON INSTITUTE  
98 Halifax Street East, Nelson 7010 | Private Bag 2, Nelson 7042 | New Zealand  
Ph. +64 3 548 2319 | Fax. +64 3 546 9464  
[www.cawthron.org.nz](http://www.cawthron.org.nz)

REVIEWED BY:  
Paul Barter



APPROVED FOR RELEASE BY:  
Natasha Berkett



---

ISSUE DATE: 22 April 2016

RECOMMENDED CITATION: Berthelsen A, Morrisey D 2016. Blenheim sewage treatment plant receiving environment monitoring 2016. Prepared for Marlborough District Council. Cawthron Report No. 2827. 30 p. plus appendices.

© COPYRIGHT: This publication must not be reproduced or distributed, electronically or otherwise, in whole or in part without the written permission of the Copyright Holder, which is the party that commissioned the report.



## EXECUTIVE SUMMARY

The Blenheim Sewerage Treatment Plant (BSTP) is owned and operated by the Marlborough District Council (MDC) and treats residential and commercial wastewater from the Blenheim urban area, as well as from some nearby industries.

In 2010 the MDC was granted consent for the upgrade and operation of the BSTP and the upgrade was completed in 2014. Consent conditions require benthic surveys and water quality monitoring to be conducted in the receiving environment of the wastewater discharge in the Wairau Estuary. The consent requires for any changes, notably adverse ecological impacts, as a result of the treated wastewater discharge to be identified.

In 2016 Cawthron Institute was commissioned to monitor the BSTP receiving environment and benthic surveys and water quality sampling were conducted in late January and early February.

### Summary of results

- Some minor environmental and ecological differences were apparent between the 2006 and 2016 surveys.
- No overall adverse ecological effects of the BSTP discharge (and no breaches of the water quality consent conditions) were detected.
- This result is likely due to the quality of the discharge and its release only on the ebb tide, as well as the rapid tidal flushing that occurs within the vicinity of the outfall.



## TABLE OF CONTENTS

1. INTRODUCTION .....	1
1.1. Report scope and objectives .....	1
2. METHODS .....	2
2.1. Subtidal benthic surveys.....	2
2.1.1. <i>Survey stations</i> .....	2
2.1.2. <i>Sediment</i> .....	3
2.1.3. <i>Infauna</i> .....	4
2.1.4. <i>Shellfish</i> .....	5
2.2. Water quality surveys .....	5
2.2.1. <i>Survey stations</i> .....	5
2.2.2. <i>Water quality</i> .....	6
3. RESULTS .....	8
3.1. Sediment .....	8
3.1.1. <i>Visual description of sediment cores</i> .....	8
3.1.2. <i>Physical and chemical properties of the sediment</i> .....	8
3.1.3. <i>Comparison with the 2006 survey</i> .....	12
3.2. Infauna .....	13
3.2.1. <i>Density and species richness</i> .....	13
3.2.2. <i>Diversity and evenness</i> .....	13
3.2.3. <i>Community analyses</i> .....	15
3.2.4. <i>Comparison with 2006</i> .....	17
3.3. Shellfish bioaccumulation .....	18
3.3.1. <i>Shellfish metal/metalloids</i> .....	18
3.3.2. <i>Shellfish bacteria</i> .....	20
3.3.3. <i>Comparison with 2006</i> .....	20
3.4. Water.....	21
3.4.1. <i>Visual description of water samples</i> .....	21
3.4.2. <i>Metal/metalloids</i> .....	21
3.4.3. <i>Nutrients, TSS and BOD</i> .....	21
3.4.4. <i>Water bacteria</i> .....	23
3.4.5. <i>Water hydrological parameters</i> .....	24
3.4.6. <i>Comparison with 2006</i> .....	25
4. DISCUSSION.....	27
4.1. Ecological changes associated with the wastewater discharge.....	27
4.1.1. <i>Sediment</i> .....	27
4.1.2. <i>Infauna</i> .....	27
4.1.3. <i>Shellfish</i> .....	27
4.1.4. <i>Water quality</i> .....	28
4.2. Summary .....	29
5. ACKNOWLEDGMENTS.....	29
6. REFERENCES .....	30
7. APPENDICES .....	31

## LIST OF FIGURES

Figure 1.	Location of the twelve subtidal ecology and sediment/shellfish quality stations downstream of the BSTP outfall in the Wairau Estuary.....	2
Figure 2.	Location of the three water quality sampling stations in the Wairau Estuary. ....	6
Figure 3.	Trace metal concentrations in sediments sampled in 2016 at twelve stations from the BSTP outfall to 300 m downstream (DS), inside (P) and outside (O) the discharge plume. ....	9
Figure 4.	Percent particle grain size distribution in sediments sampled in 2016 at twelve stations from the BSTP outfall to 300 m downstream, inside (P) and outside (O) the discharge plume.. ....	11
Figure 5.	Percent organic content (as organic matter) of sediment sampled in 2016 at twelve stations from the BSTP outfall to 300 m downstream inside (P) and outside (O) the discharge plume.....	12
Figure 6.	Abundance and species richness in 2016 at twelve stations from the BSTP outfall to 300 m downstream (DS), inside (P) and outside (O) the discharge plume. ....	14
Figure 7.	Pielou's evenness and Shannon-Weiner diversity in 2016 at twelve stations from the BSTP outfall to 300 m downstream (DS), inside (P) and outside (O) the discharge plume. ....	15
Figure 8.	Amphipod from the family Corophiidae.....	16
Figure 9.	Non-metric MDS of infauna communities in 2016 collected at twelve stations from the BSTP outfall to 300 m downstream, inside (P) and outside (O) the discharge plume. ....	17
Figure 10.	Trace metal/metalloid concentrations in pipi shellfish tissue sampled in 2016 from nine stations at the BSTP outfall (OF) to 300 m downstream (DS), inside (P) and outside the plume (O). ....	19
Figure 11.	Faecal coliform levels (MPN/100G) in tissue of pipi ( <i>Paphies australis</i> ) sampled in 2016 from nine stations at the BSTP outfall (OF) to 300 m downstream inside (P) and outside (O) the plume. ....	20
Figure 12.	Water nutrient (nitrogen, total ammoniacal-N and dissolved reactive phosphorus) bacteriological results (faecal coliform and enterococci) and total suspended solids (TSS) for near-surface (S) and near-bed (B) water samples in 2016 from three stations at varying distances from the BSTP outfall.....	23
Figure 13.	Hydrological profiles in 2016 from three stations at varying distances from the BSTP outfall.....	26

## LIST OF TABLES

Table 1.	Summary of analytes and analytical methods used by Hill Laboratories for sediments.....	3
Table 2.	Description of infauna community indices. ....	4
Table 3.	Summary of analytes and analytical methods used for shellfish. ....	5
Table 4.	Summary of analytes and analytical methods for water quality.....	7
Table 5.	Water metal/metalloid concentrations (g/m <sup>3</sup> ) for near-surface (S) and near-bed (B) water samples from the three water sampling stations: upstream (US), mixing zone (MZ) and bar (B). ANZECC 2000 values are triggers for slightly to moderately disturbed systems in marine waters.....	21
Table 6.	Salinity and pH of near-surface and near-bed water samples in 2016 from three stations at varying distances from the BSTP outfall. ....	24

## LIST OF APPENDICES

Appendix 1. Consent (U071181) conditions 58, 59 (a-c) and 60 G (Part II).....	31
Appendix 2. Locations (in decimal degrees) of 2016 benthic survey stations in the Wairau Estuary. .	32
Appendix 3. Locations (in decimal degrees) of 2016 water sampling stations in Wairau the Estuary.	33
Appendix 4. Sediment core photos. ....	34
Appendix 5. Infauna data from all benthic survey stations. ....	36
Appendix 6. One-way SIMPER analysis based on Bray Curtis similarity (with a 70% cut off for low contributions) of infauna communities from all benthic survey stations in Wairau Estuary (n = 3). ....	38





# 1. INTRODUCTION

The Blenheim Sewerage Treatment Plant (BSTP) is owned and operated by the Marlborough District Council (MDC) and treats residential and commercial wastewater from the Blenheim urban area, as well as from some nearby industries. In 2010 the MDC was granted consent (U071181) for the upgrade and operation of the BSTP. Prior to the granting of this consent, Cawthron Institute (Cawthron) produced a technical report on effects of outfall discharge as a component of an assessment of environmental effects (Appendix D of CH2M Beca 2007, referenced as Barter et al. 2006).

The upgrade was completed in February 2014 and included the construction of a series of wetland cells. The combined treated flows are conveyed by these cells from the domestic and industrial pond systems to a new outfall in the Wairau Estuary (CH2M Beca 2014). Consent conditions G63 through 69 (Part II) require benthic surveys and water quality monitoring in the receiving environment to identify changes, notably adverse ecological impacts as a result of the treated wastewater discharge. Consent conditions G59 and G60 (Part II) also outline conditions relating to water quality and biological growths in relation to the discharge (Appendix 1). The survey design was to be consistent with Barter et al. (2006) and the monitoring was required to be undertaken within 12–24 months of commissioning the new outfall pipeline.

## 1.1. Report scope and objectives

Cawthron was commissioned to undertake monitoring of the BSTP receiving environment between February and March 2016. The scope of this work was to:

- Undertake **benthic surveys** at twelve stations (six pairs, located inside and outside the wastewater plume) at specified distances downstream of the outfall. Benthic surveys to include monitoring of the following:
  - infaunal communities
  - shellfish contamination
  - sediment characteristics and contamination
- Undertake near-surface and near-bed **water quality sampling** at three stations at specified distances from the outfall during the ebb tidal discharge.
- **Report** the results and contrast them with those of Barter et al. (2006). Include the identification of any adverse ecological impacts or other change related to the treated wastewater discharge.

## 2. METHODS

All fieldwork was undertaken on 29 January and 3 February 2016. The sampling methods for benthic surveys and water sampling are outlined below, however Barter et al. (2006) can be referred to for further details on the benthic surveys. Previous studies showed a narrow and consistent pattern in the location of the effluent plume which allowed the side-by-side comparison of the in-plume vs out-of-plume sampling approach adopted here.

### 2.1. Subtidal benthic surveys

#### 2.1.1. Survey stations

Benthic surveys were conducted at six distances (< 5 m, 25 m, 50 m, 100 m, 200 m and 300 m) downstream of the outfall in the Wairau Estuary. At each distance, sampling was conducted at two different stations, one inside the wastewater discharge plume and one outside of the plume. In total twelve stations were sampled (Figure 1, Appendix 2).

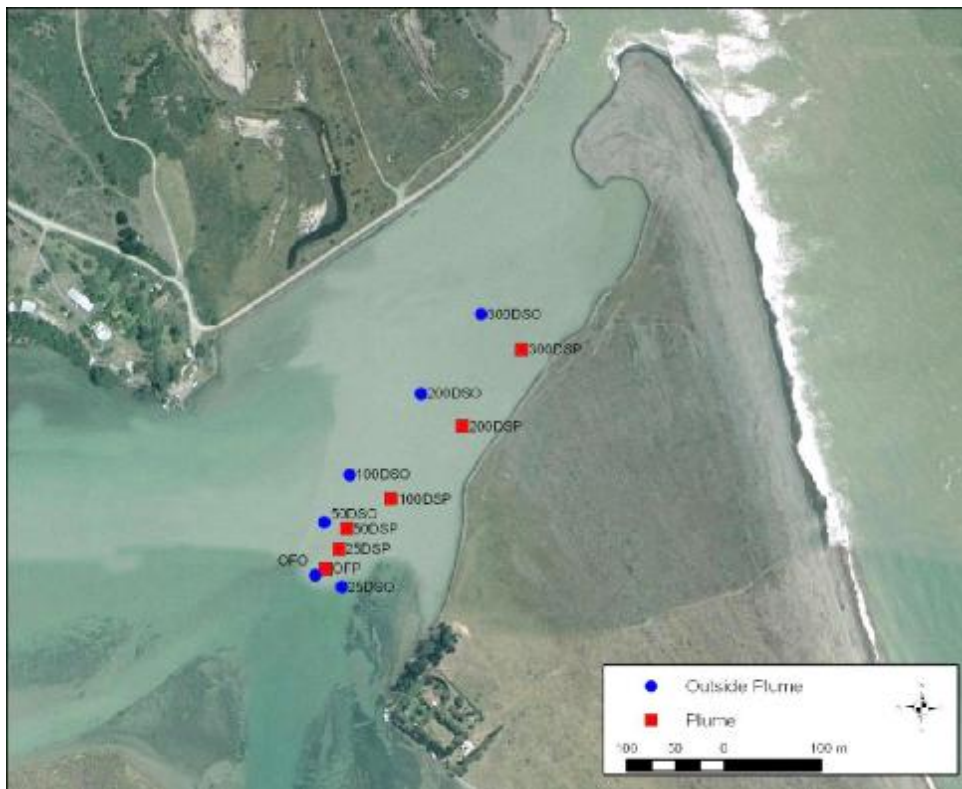

Figure 1. Location of the twelve subtidal ecology and sediment/shellfish quality stations downstream of the BSTP outfall in the Wairau Estuary, showing inside and outside plume sampling points for each station.

### 2.1.2. Sediment

Sediment samples (three replicate cores) were collected at each of the twelve stations (described above). The corers (60 mm in diameter) were driven manually into the sediment to a depth of between 10 and 15 cm by SCUBA divers, capped *in situ* and returned to the support vessel. Each sample was extruded from the corer and the colour profile, presence or absence of anoxic patches within the sample, and depth of any apparent redox potential discontinuity (aRPD)<sup>1</sup> layer were recorded. The cores were then photographed to provide a visual record. The top 5 cm of each core was subsampled to create two samples, one in which the replicates were composited for the analysis of trace metals/metalloids arsenic (As), cadmium (Cd), chromium (Cr), copper (Cu), mercury (Hg), nickel (Ni), lead (Pb), zinc (Zn) and one for the analysis of particle grain size and organic content. The samples were placed into plastic jars and stored chilled until arrival at Hill Laboratories who conducted the analyses (Table 1).

Table 1. Summary of analytes and analytical methods used by Hill Laboratories for sediments.

Analyte	Method Description
Sediment grain size	Wet-sieved using dispersant, gravimetry (calculation by difference) Screen sizes: >2 mm = Gravel <2 mm – >1 mm = Coarse Sand <1 mm - >500 µm = Medium Sand <500 µm - >250 µm = Medium/Fine Sand <250 µm - >125 µm = Fine Sand <125 µm - >63 µm = Very Fine Sand <63 µm = Mud (Silt & Clay)
Organic Matter	Calculation: 100g – Ash (dry wt)
Trace metals/metalloids	Dried sample, <2mm fraction. Nitric/Hydrochloric acid digestion, ICP-MS, trace level

Results of sediment chemical analyses were compared with national sediment quality guidelines (ANZECC 2000), where applicable. The Interim Sediment Quality Guideline-Low (ISQG-Low) and Interim Sediment Quality Guideline-High (ISQG-High) trigger values represent two distinct threshold levels above which biological effects are predicted. The lower threshold (ISQG-Low) indicates a *possible* biological effect and is intended as a trigger value for further investigation, while the upper threshold (ISQG-High) indicates a *probable* biological effect.

<sup>1</sup> The apparent redox potential discontinuity depth (aRPD) refers to the often distinct colour change, between surface and underlying sediments, brought about by the changing redox environment with depth in the profile. This gradient of colour change is in reality continuous but may be reduced to an average transition point (sediment depth) for descriptive purposes.

### 2.1.3. Infauna

Infauna were collected at each of the twelve stations in three replicate cores. PVC corers (130 mm diameter) were manually driven 100 mm into the sediments by divers, the sediments were withdrawn and brought back to the support vessel where the cores were sieved through a 0.5-mm mesh. The sieve residue containing the infauna was preserved in 70% ethanol with 5% glyoxal as a fixative. Infauna were counted and identified to the lowest practicable level of taxonomic resolution.

Numbers of individuals and numbers of species were obtained for each sample and used to calculate the Shannon-Weiner diversity and Pielou's evenness indices (Table 2). These indices are useful for comparisons between stations and with historical information.

Table 2. Description of infauna community indices.

Index	Description
Abundance (N)	Total number of individual organisms in a sample.
Species richness (S)	Total number of species in a sample.
Diversity ( $H' \log_e$ )	Shannon-Wiener diversity index ( $\log_e$ base). A diversity index that describes, in a single number, the different types and amounts of animals present in a collection. Varies with both the number of species and the relative distribution of individual organisms among the species. The index ranges from 0 for communities containing a single species to high values for communities containing many species with each represented by a small number of individuals.
Evenness ( $J'$ )	Pielou's evenness. A measure of equitability, or how evenly the individuals are distributed among the different species. Values can theoretically range from 0.00 to 1.00, where a high value indicates an even distribution and a low value indicates an uneven distribution or dominance by a few taxa.

The infaunal assemblage data were contrasted using non-metric multidimensional scaling ordination following square-root transformation to de-emphasise the influence of the dominant species (nMDS; Kruskal & Wish 1978). This analysis compared replicate samples and grouped them into discrete clusters, or groups, based on their similarity. One-way similarity percentage analysis (SIMPER), using station as the factor and based on a 70% cut-off for low contributions, was used to identify taxa responsible for similarities among samples. All multivariate analyses were based on Bray-Curtis similarities and conducted using the software PRIMER v7 (PRIMER-E 2000; Clarke & Warwick 1994; Clarke & Gorley 2001).

### 2.1.4. Shellfish

When present, approximately 15–22 pipi (*Paphies australis*) were collected manually by a diver from each station. The pipi were stored chilled until they were analysed for faecal coliforms and trace metals/metalloids (As, Cr, Cu, Hg, Ni, Pb, Zn) (Table 3).

Table 3. Summary of analytes and analytical methods used for shellfish.

Analyte	Laboratory	Method Description
Faecal coliforms	Cawthron Analytical Services	Compendium 4 <sup>th</sup> edition 2001
Trace metals/metalloids	Hill Laboratories	Biological materials digestion, ICP-MS (Chromium also with dynamic reaction cell)

Concentrations of metals in shellfish were compared against the 2015 Australia New Zealand Food Standard Code: Standard 1.4.1, Contaminants and natural toxicants. (ANZFSC 2015). Shellfish bacteriological results were compared against the Ministry of Health Reference Criteria for Food (MOH 1995).

## 2.2. Water quality surveys

### 2.2.1. Survey stations

Water quality surveys were conducted at three stations: 400 m upstream of the discharge; at the downstream edge of the mixing zone 300 m downstream of the discharge; and at the bar entrance 550 m downstream of the discharge (Figure 2, Appendix 3).



Figure 2. Location of the three water quality sampling stations in the Wairau Estuary. Distances are in relation to the BSTP outfall.

### ***2.2.2. Water quality***

Two water samples, one within 1 m of the surface (near-surface) and one within 1 m of the seabed (near-bed), were collected during the ebb tide discharge at each of the three water quality survey stations. Water samples were collected using a horizontally-mounted van Dorn sampler (2 L). Each water sample was split into two subsamples, one for analysis of faecal coliforms and enterococci by Cawthron Analytical Services and one for analysis of total suspended solids (TSS), biochemical oxygen demand (as BOD<sub>5</sub>), total ammoniacal-N, dissolved reactive phosphorous and trace metals/metalloids by Hill Laboratories (Table 4). The salinity and pH of all water samples was measured in the field using a YSI Pro plus Multimeter (calibrated December 2015). One CTD (conductivity, temperature and depth) instrument cast (using a Seabird SBE19plus V2) was also conducted from the surface to the bed and back at each of the water sampling stations to measure turbidity, dissolved oxygen, temperature, light (as photosynthetically active radiation, PAR) and salinity. CTD data output was trimmed during post-processing to include upcast data only and to exclude data shallower than 0.5 m depth.

Table 4. Summary of analytes and analytical methods for water quality.

Analyte	Laboratory	Method Description
Faecal Coliforms	Cawthron Analytical Services	APHA Seawater Shellfish 4 <sup>th</sup> Edn
Enterococci	Cawthron Analytical Services	APHA (online) 9230D
Total Arsenic	Hill Laboratories	
Total Chromium		Nitric acid digestion, ICP-MS with dynamic reaction cell, ultratrace. APHA 3125 B 22nd ed. 2012.
Total Copper		
Total Zinc		
Total Cadmium	Hill Laboratories	Nitric acid digestion, ICP-MS, ultratrace level. APHA 3125 B 22nd ed. 2012.
Total Lead		
Total Mercury	Hill Laboratories	Bromine Oxidation followed by Atomic Fluorescence. US EPA Method 245.7, Feb 2005.
Total Nickel	Hill Laboratories	Nitric acid digestion, ICP-MS with universal cell, ultratrace. APHA 3125 B 22nd ed. 2012.
Total Suspended Solids	Hill Laboratories	Saline sample. Filtration using Whatman 934 AH, Advantec GC-50 or equivalent filters (nominal pore size 1.2 - 1.5µm), gravimetric determination. APHA 2540 D 22nd ed. 2012.
Total Nitrogen Digestion	Hill Laboratories	Caustic persulphate digestion. APHA 4500-N C 22 <sup>nd</sup> ed. 2012
Total Ammoniacal-N	Hill Laboratories	Saline, filtered sample. Phenol/hypochlorite colorimetry. Discrete Analyser. (NH <sub>4</sub> -N = NH <sub>4</sub> <sup>+</sup> -N + NH <sub>3</sub> -N). APHA 4500-NH <sub>3</sub> F (modified from manual analysis) 22nd ed. 2012.
Dissolved Reactive Phosphorous	Hill Laboratories	Saline sample. Molybdenum blue colorimetry. Flow injection analyser. APHA 4500-P G 22nd ed. 2012.
Total Biochemical Oxygen Demand	Hill Laboratories	Incubation 5 days, DO meter, no nitrification inhibitor added, seeded. Analysed at Hill Laboratories - Microbiology; 1 Clow Place, Hamilton. APHA 5210 B (modified) 22nd ed. 2012.

Values of water-quality variables were compared against ANZECC (2000) default trigger values for physical and chemical stressors, where these are available. The trigger values were those for slightly disturbed south-east Australian estuaries and marine water (total nitrogen and total ammoniacal-N) and slightly to moderately disturbed marine water systems (metals/metalloids). Bacteriological results (faecal coliform and enterococci) for water were compared against ANZECC (2000) guidelines for primary and secondary contact as well as against (Ministry for the Environment's (MfE) (2003) guidelines for surveillance, alert and action modes. Water temperature, dissolved oxygen and visual clarity were compared against the relevant consent conditions for water quality of the BSTP discharge receiving environment.



## 3. RESULTS

### 3.1. Sediment

In the following results, benthic survey stations are described according to their distance downstream (DS) of the outfall (25, 50, 100, 200 and 300 m) with OF representing stations within < 5 m of the outfall. Position inside and outside of the plume are represented by P and O respectively.

#### *3.1.1. Visual description of sediment cores*

Organic matter, including some seaweed, was visible in cores at the OFP, 25DSP and 50DSP stations. Sediments inside the plume were generally grey at all stations, although there was some variation in colour between stations (Appendix 4). The sediment cores at most stations did not smell, however a slight sulphide smell was detected in cores at 50DSP and 100DSO and a strong smell was detected in cores at OFP.

#### *3.1.2. Physical and chemical properties of the sediment*

All trace metals in sediments, excluding nickel, were below ANZECC (2000) ISQG-low guidelines (Figure 3). Nickel exceeded the ISQG-Low (but not ISQG-High) criteria at all stations and was highest at OFO, OFP, 50DSO and 50DSP. The concentrations of all other metals/metalloids were spatially consistent and did not display any patterns in relation to distance from the outfall, or by position inside or outside the plume.

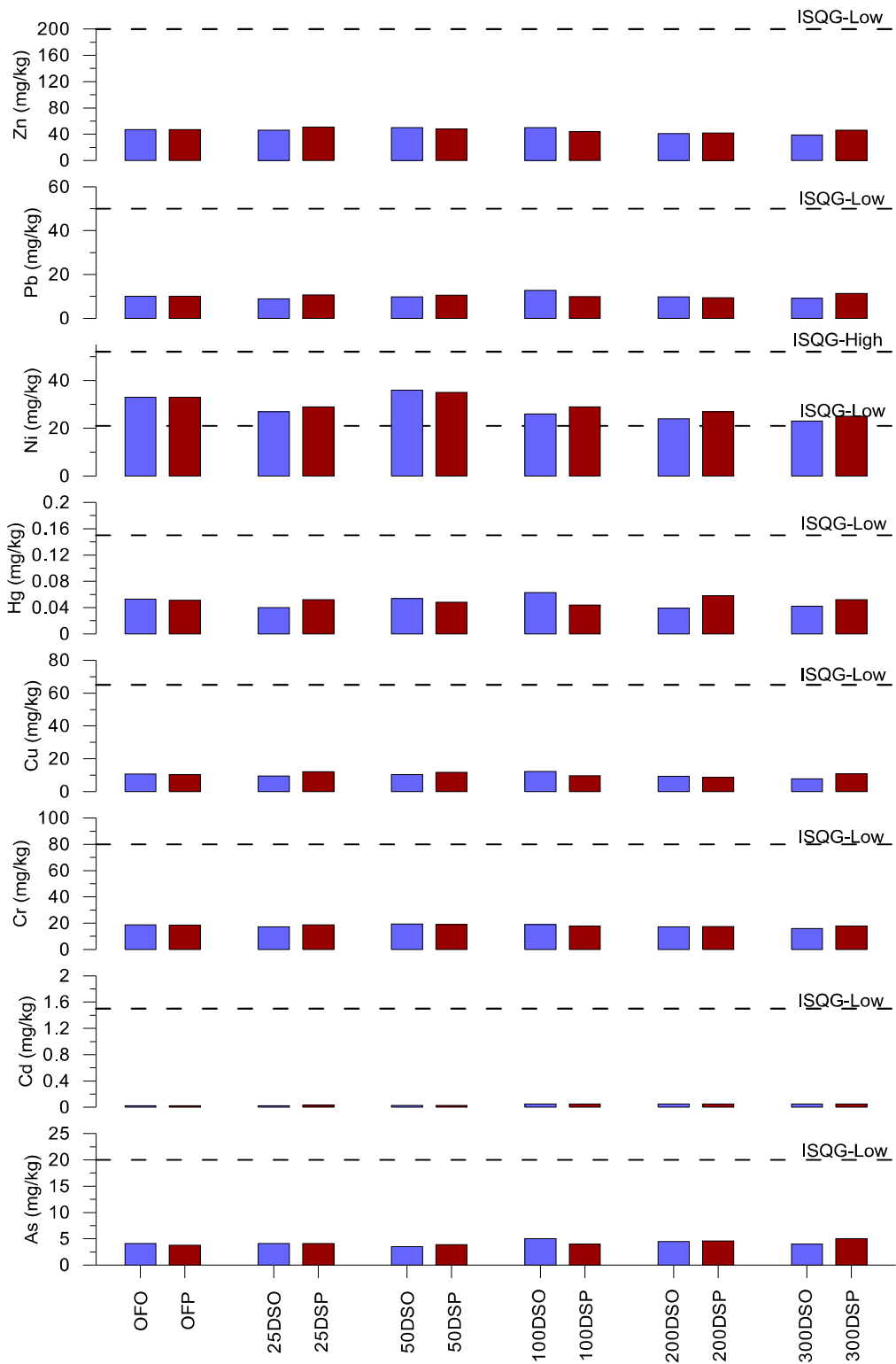

Figure 3. Trace metal concentrations in sediments sampled in 2016 at twelve stations from the BSTP outfall to 300 m downstream (DS), inside (P) and outside (O) the discharge plume. Data are values from composites of three sediment cores per station. Note: Cadmium concentration was below the detection limit at some stations, and where this occurred the value shown is half the detection limit. Trigger levels for ISQG-Low (and ISQG-High for nickel) (ANZECC 2000) are displayed.

There were no obvious patterns in sediment grain size in relation to the overall distance gradient from the outfall, or position inside and outside the discharge plume (Figure 4). Sediment cores from most stations were generally dominated by grains smaller than 500  $\mu\text{m}$  (the same size or smaller than medium sand). Silt and clay particles (the smallest particles at  $< 63 \mu\text{m}$ ) for all stations ranged between 1.4–40.3% and average values were highest ( $39.1\% \pm 0.6 \text{ SE}$ ) at 100DSO and lowest ( $1.4\% \pm 0.03 \text{ SE}$ ) at 300DSO. Sediment cores at stations 25DSP, 25DSO and 200DSP had a higher percentage of larger grain sizes (coarse and very coarse sand, gravel). For example, the average amount of gravel (grain size  $> 2 \text{ mm}$ ) at most stations was less than 1%, however at 200DSP and 25DSO average gravel values were  $16.8\% (\pm 9.4 \text{ SE})$  and  $25.6\% (\pm 3.3 \text{ SE})$ , respectively.

There were no obvious patterns in the organic content (as % organic matter) of sediments in relation to the distance gradient downstream from the outfall or position inside and outside the plume (Figure 5). Organic content values ranged from 1.7–3.2% of dry weight with the highest average value ( $3.1\% \pm 0.07 \text{ SE}$ ) at 25DSP, and the lowest average value ( $1.7\% \pm 0.01 \text{ SE}$ ) at 50DSO.

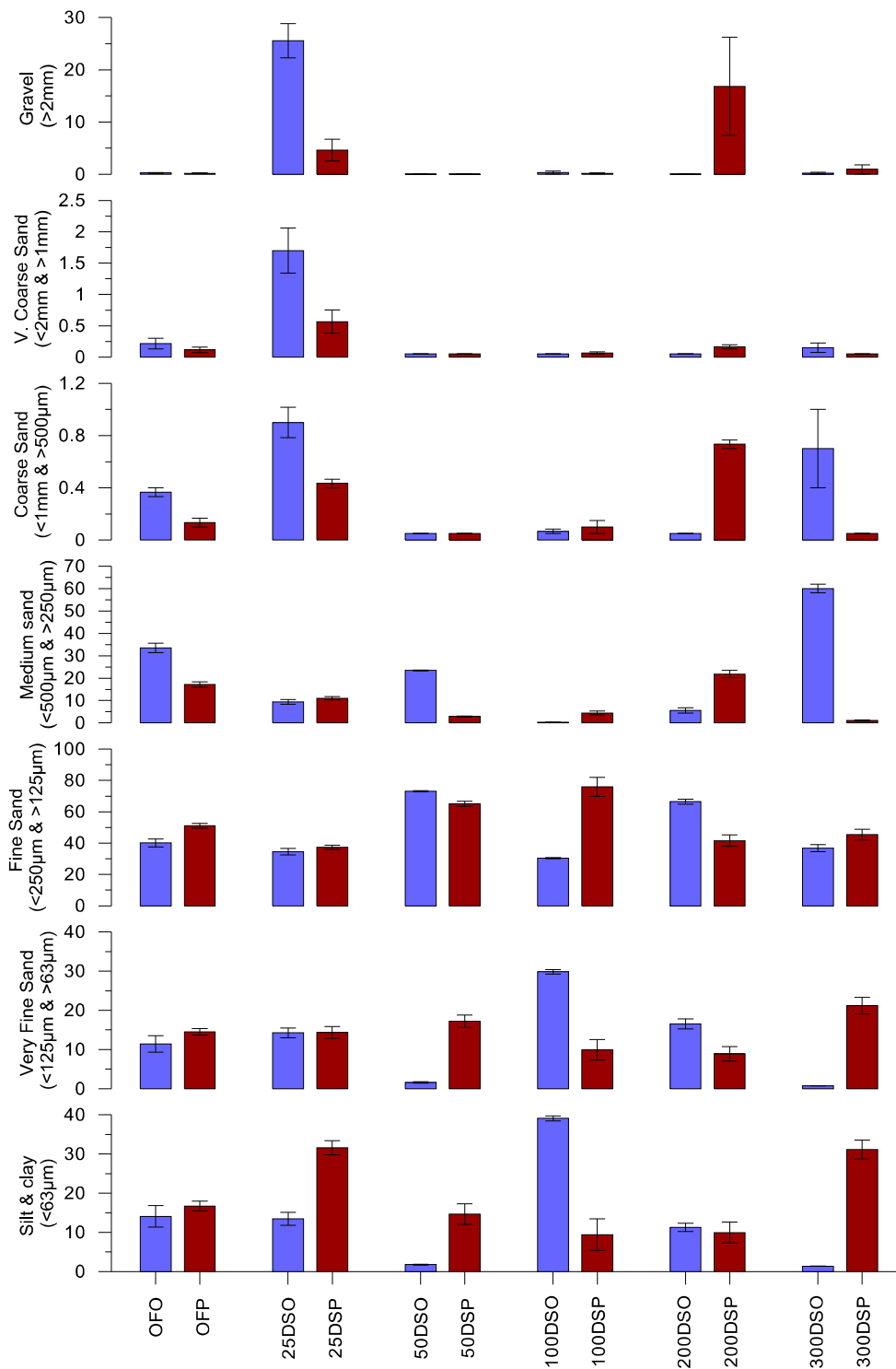

Figure 4. Percent particle grain size distribution in sediments sampled in 2016 at twelve stations from the BSTP outfall to 300 m downstream, inside (P) and outside (O) the discharge plume. Data are average percentage values ( $\pm 1$  SE),  $n = 3$ . Note: where grain size values were reported as  $< 0.1$  in the results, this value was halved for graph display purposes.

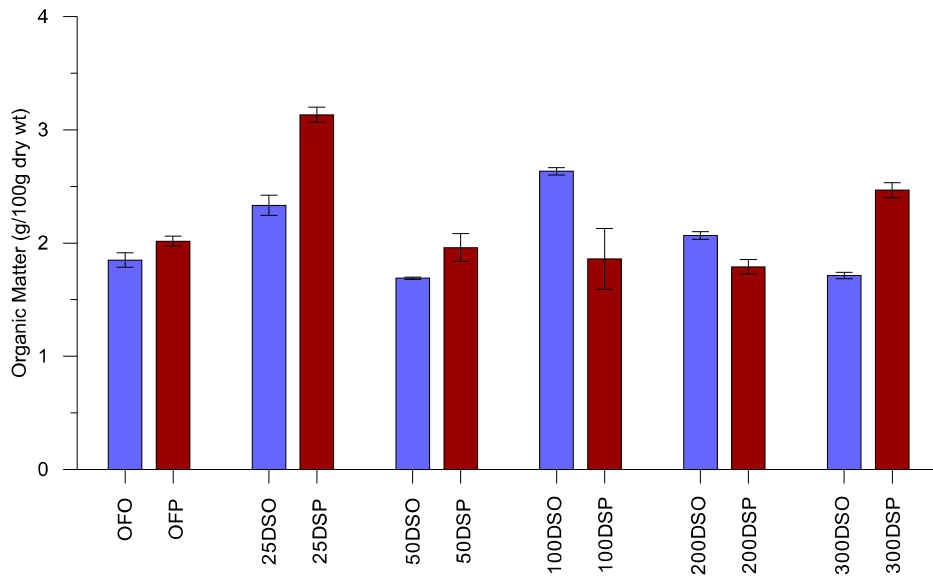

Figure 5. Percent organic content (as organic matter) of sediment sampled in 2016 at twelve stations from the BSTP outfall to 300 m downstream inside (P) and outside (O) the discharge plume. Data are mean values ( $\pm 1$  SE),  $n = 3$ .

### 3.1.3. Comparison with the 2006 survey

Sulphide odour was detected in sediment cores in 2016 although these were generally closer to the outfall and both within and outside the plume, compared to 2006 where a sulphide odour was detected at stations 200DSP and 300DSP. In regards to sediment core colour, in 2016 a slight redox layer was recorded within some cores, however similar to 2006 results, core colour overall was variable with no obvious gradient in relation to distance from the outfall or overall pattern in relation to position inside or outside the plume.

In 2016 and 2006 all metal concentrations (except for nickel) were below ISQG-Low criteria. Nickel concentrations in sediment cores were well below the ISQG-High criterion in 2016 although they were close at one station in 2006; however, in 2016 more stations were above the ISQG-Low criteria compared to 2006. In 2016, metals/metalloids in sediment did not display any obvious patterns in regards to the distance gradient downstream of outfall or position inside and outside the plume, however in 2006 some metals (chromium, copper, mercury, lead, zinc) were slightly elevated near the outfall compared to other stations.

Silt and clay was not as dominant in the sediment at stations OFO and OFP in 2016 (around 10–20%) as it was in 2006 (around 60–80%). In 2016 grain size did not display any obvious gradient in relation to the distance gradient downstream of outfall or overall pattern in relation to position inside and outside the plume. In 2006,

however, stations closer to the outfall had higher proportions of silt and clay particles and from 100 – 300 m sediments consisted largely of fine to medium sand.

In 2016 there were no obvious patterns in organic content in relation to distance from the outfall and position inside and outside the discharge plume. In 2006 organic content (as ash-free dry weight) was highest at stations OFO and 25DSO.

## 3.2. Infauna

### 3.2.1. Density and species richness

The abundances of infaunal individuals from all stations ranged from 0–61 individuals per core (Figure 6: the full set of infauna count data are presented in Appendix 5). The average abundance was highest at 25DSO ( $55.7 \pm 3.2$  SE individuals per core) and lowest at 300DSO ( $3.7 \pm 2.03$  SE individuals per core). Average abundance was relatively constant at stations within the plume and more variable at stations outside the plume. Average abundance outside the plume was highest at OFO and 25DSO, and was higher outside of the plume compared to within the plume at these stations.

Species richness at all stations ranged from 0–18 taxa per core. The highest average number of taxa ( $17.3 \pm 0.7$  SE taxa per core) occurred at 25DSO. The lowest species richness ( $3 \pm 1.5$  SE taxa per core) was recorded at 300DSO. Average species richness displayed a similar pattern to average abundance.

### 3.2.2. Diversity and evenness

The Shannon-Weiner diversity of infauna communities at all stations ranged from 0–2.5 per core (Figure 7). The average diversity was highest at 25DSO ( $2.4 \pm 0.06$  SE) and lowest at 300DSO ( $1.0 \pm 0.5$  SE). In regards to infauna communities within the plume, diversity was highest at distances from 100 m and further downstream of the plume. For communities outside of the plume there was no gradient pattern in relation to distance downstream of the outfall. The average diversity was higher outside the plume (compared to inside the plume) at distances from 50 m or less from the outfall.

Pielou's evenness at all stations ranged from 0.5–1.0 per core (Figure 7). The average evenness was highest at 300DSO ( $1.0 \pm 0.003$  SE), although at this station the average was calculated from only two (rather than three) samples as one sample contained no infauna. The average evenness was lowest at OFP ( $0.6 \pm 0.04$  SE).

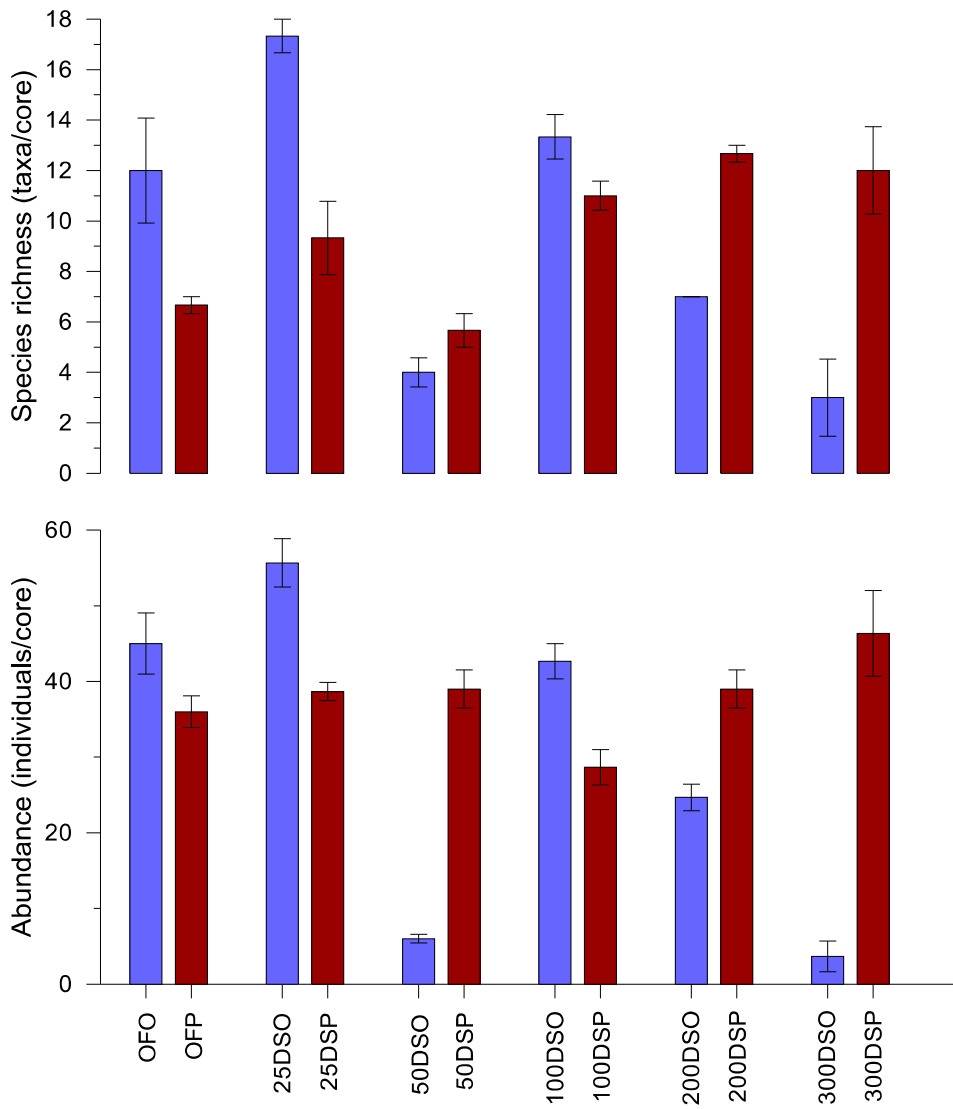

Figure 6. Abundance and species richness in 2016 at twelve stations from the BSTP outfall to 300 m downstream (DS), inside (P) and outside (O) the discharge plume. Data are mean values ( $\pm$  SE), n = 3.

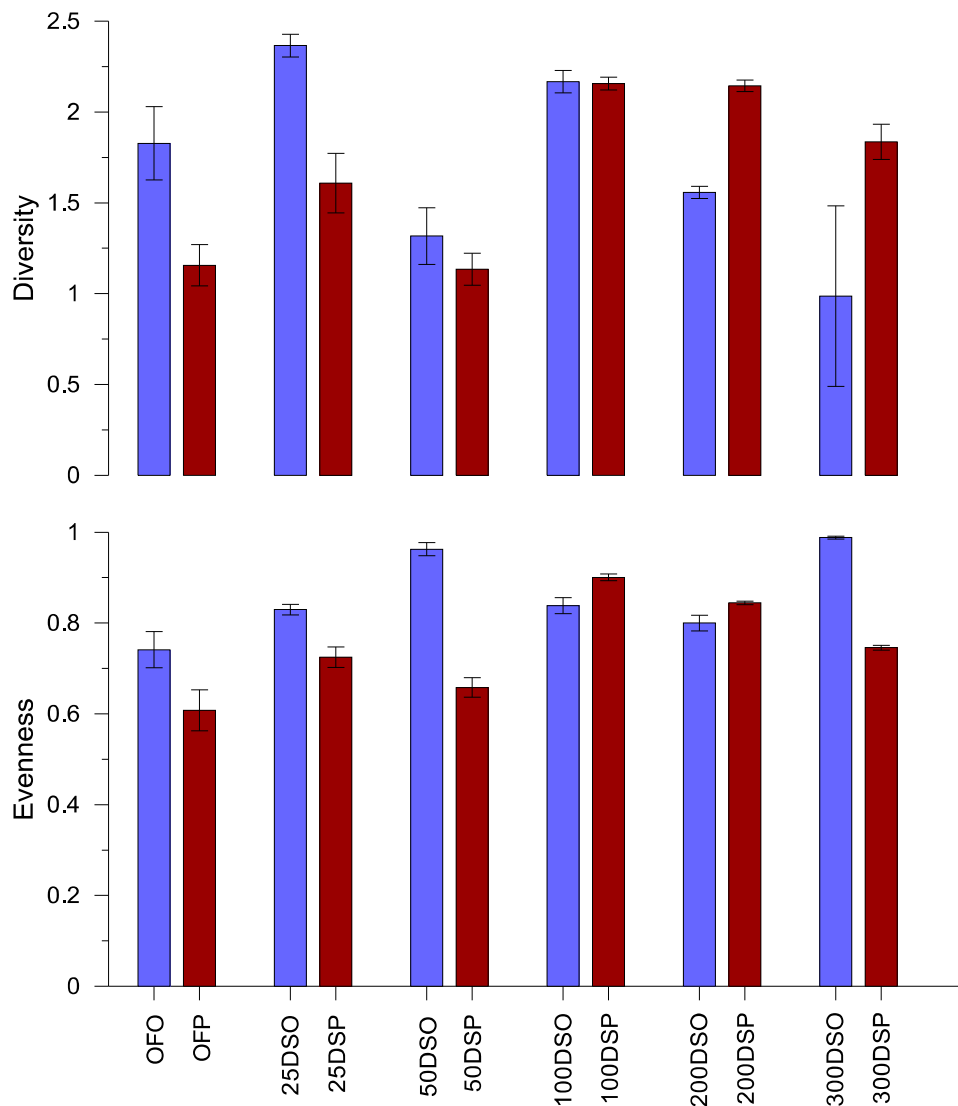

Figure 7. Pielou's evenness and Shannon-Weiner diversity in 2016 at twelve stations from the BSTP outfall to 300 m downstream (DS), inside (P) and outside (O) the discharge plume. Data are mean values ( $\pm$  SE) and  $n = 3$  (except for diversity at 300DSO where  $n = 2$ ).

### 3.2.3. Community analyses

Multivariate SIMPER analysis (Appendix 6) showed that similarity among replicate cores within stations ranged from 25.3% at 300DSO to 84.7% at 25DSP. Amphipods (including those from the family Corophiidae; Figure 8) were the dominant taxa within infaunal communities at all stations except for 50DSO (where pipi were dominant), 300DSO (mysid shrimp, Mysidacea) and 25DSO and 200DSP (the barnacle *Austrominius modestus* was dominant in both cases).

The abundance of several families of polychaete worms have commonly been used to indicate the biotic 'health' of an area, with some taxa belonging to the family



capitellidae often associated with organic enrichment (ANZECC 2000). Polychaetes were not dominant at any of the stations although some capitellid taxa were present and at a number of sites contributed to > 10% of infaunal assemblages e.g. *Heteromastus filiformis* contributed to 21% of the infaunal assemblages at 200DSO and *Capitella capitata* contributed to 16% and *H. filiformis* to 12% of infaunal assemblages at 100DSP.

There was general grouping of replicates by station (Figure 9). There was also evidence for some weak grouping of infauna communities by position inside and outside of plume although not by distance downstream of the outfall.



Figure 8. Amphipod from the family Corophiidae.

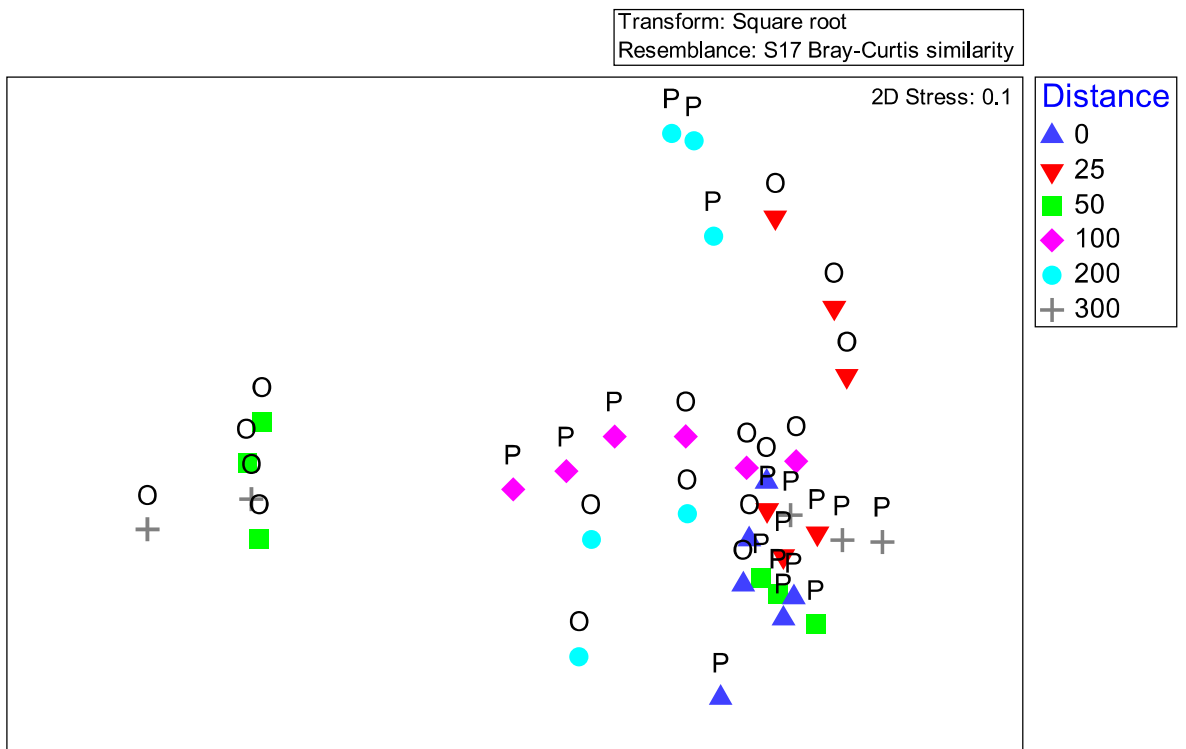

Figure 9. Non-metric MDS of infauna communities in 2016 collected at twelve stations from the BSTP outfall to 300 m downstream, inside (P) and outside (O) the discharge plume. A replicate from station 300DSO contained zero infauna and was removed from this data.

#### 3.2.4. Comparison with 2006

Infaunal abundance was lower in 2016 compared to 2006 (ranges of abundance 0–61 vs 19–145 individuals per core). Species richness, diversity and evenness values in 2016 were also spread over a wider range compared to 2006 (8–11 taxa per core, 0.8–1.6 individuals per core and 0.36–0.72 respectively). In 2006 and 2016 there were some similarities in abundance and species richness patterns, including higher variability at stations outside the plume, but no consistent patterns in either year in relation to the distance gradient downstream of the plume and position inside and outside of the plume. In 2006 and 2016 evenness and diversity were generally lower inside the plume compared to outside the plume at sites within 50 m downstream of the outfall, however overall there were no consistent patterns in either year in relation to the distance gradient downstream of the plume and position inside and outside of the plume.

Similar to 2016, amphipods (particularly those belonging to the family Corophiidae) were dominant at a number of stations in 2006, especially those closest to the outfall. However, in 2006 *Potamopygrus estuarinus* (an estuarine snail) was the dominant species from all stations 100–300 m downstream of the outfall; this species was not dominant at any of the stations in 2016. In both 2006 and 2016 polychaete taxa

indicative of enrichment (Family Capitellidae) were not dominant at any of the stations.

### **3.3. Shellfish bioaccumulation**

#### ***3.3.1. Shellfish metal/metalloids***

Pipi were found in enough abundance to sample at all stations except for 25DSO, 50DSO and 50DSP. The concentrations of each metal/metalloid across the different stations were generally relatively uniform with the exception of the lower concentrations at station OFO, and slightly higher concentrations at 100DSO (Figure 10). With the exception of arsenic, the concentrations of all other applicable metal/metalloids at all stations were lower than the maximum concentrations permitted by the ANZFSC (2015).

Arsenic concentrations ranged between 0.05–1.9 mg/kg. With the exception of station OFO, all arsenic concentrations were higher than the maximum permitted concentration for molluscs (1 mg/kg) listed by the ANZFSC (2015). Although the permitted concentrations for arsenic were exceeded, there were no distinct trends for bioaccumulation along the gradient of the plume from the outfall.

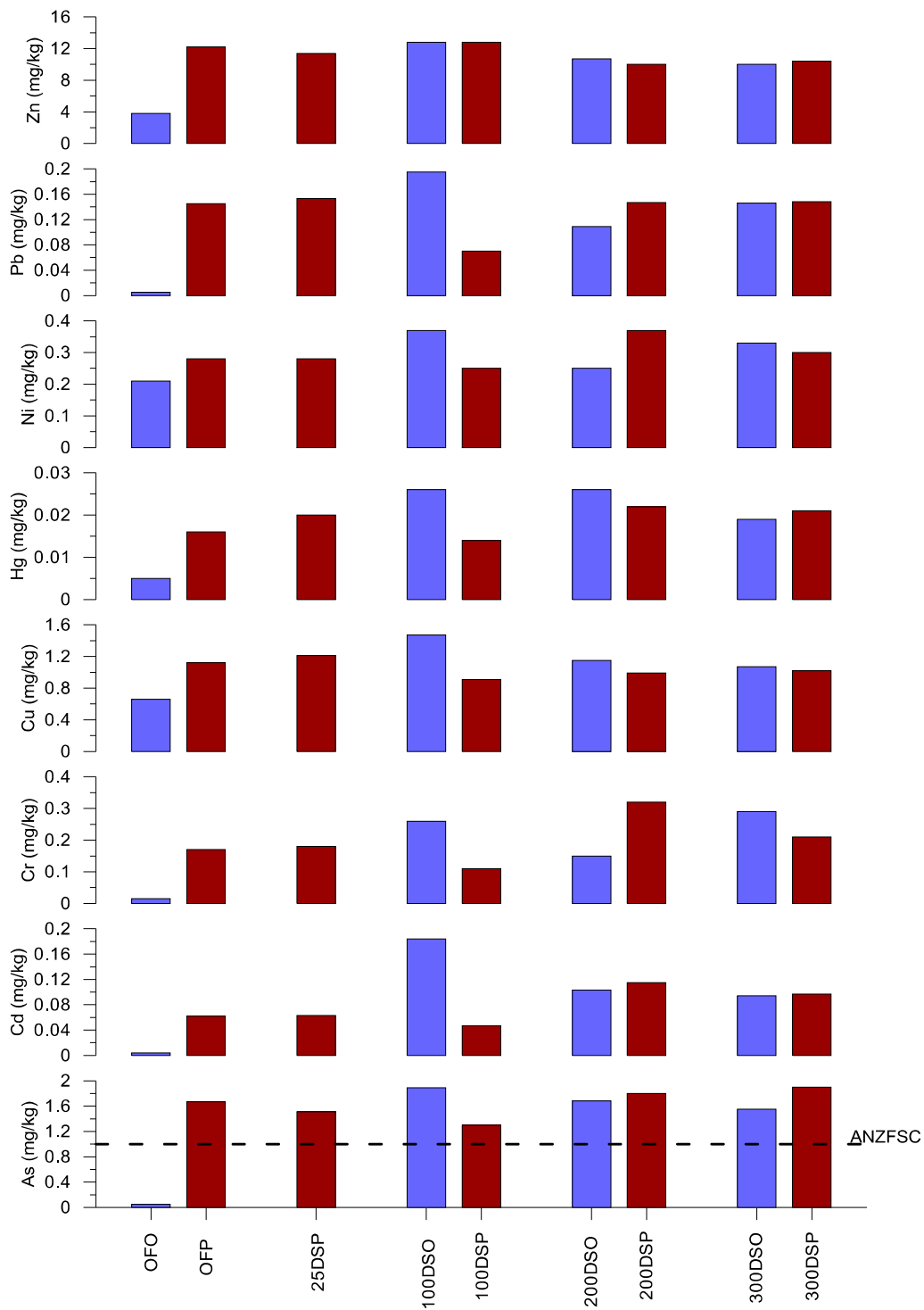

Figure 10. Trace metal/metalloid concentrations in pipi shellfish tissue sampled in 2016 from nine stations at the BSTP outfall (OF) to 300 m downstream (DS), inside (P) and outside the plume (O). Data are from tissue composites of approximately 15–22 shellfish per station. Where metal/metalloid levels were not detected, the value displayed is half of the detection limit. The ANZFSC line indicates the maximum permitted concentration.

### 3.3.2. Shellfish bacteria

Faecal coliform levels were highest (both 230 MPN/100g) at OFP and 25DSP (Figure 11). Values above this level are considered marginally acceptable for harvested and unprocessed shellfish by the Ministry of Health Reference Criteria for Food (MoH 1995). None of the sites exceeded the faecal coliform level of 330 MPN/100g considered unacceptable by the MoH (1995) guidelines. The lowest faecal coliform levels (20 MPN/100g) were present at station 200DSP.

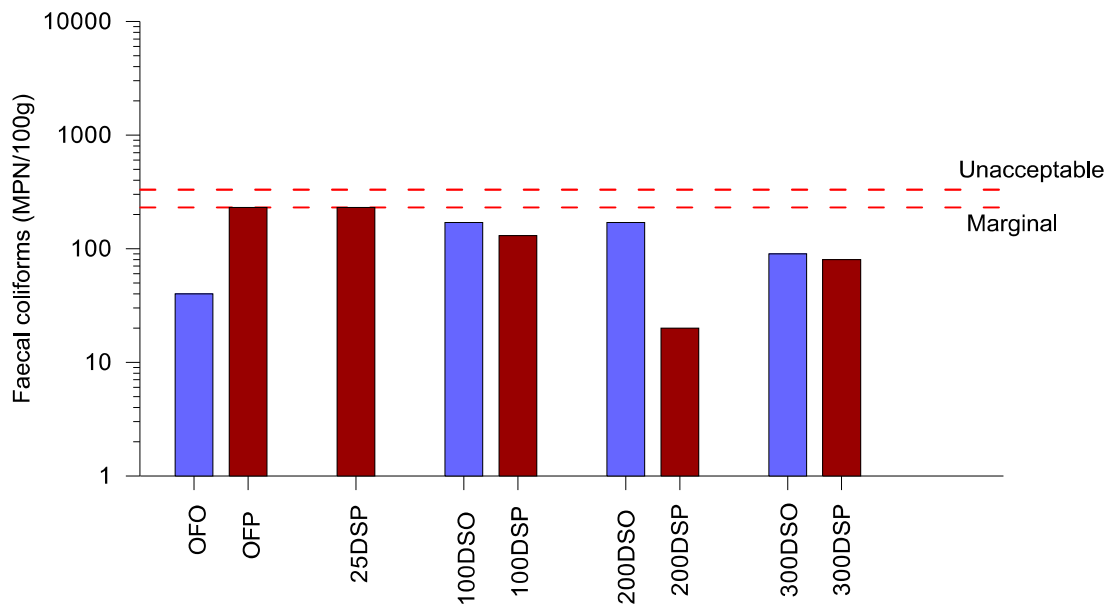

Figure 11. Faecal coliform levels (MPN/100G) in tissue of pipi (*Paphies australis*) sampled in 2016 from nine stations at the BSTP outfall (OF) to 300 m downstream inside (P) and outside (O) the plume. Numbers are average values from tissue composites of approximately 15–22 shellfish per station.

### 3.3.3. Comparison with 2006

Similar to 2006, the concentrations of arsenic (but no other metal/metalloids) were higher than recommended guidelines at all stations where pipi were collected (with the exception of station OFO in 2016). Metal concentrations were higher in 2016 at some stations (both inside and outside the plume) for zinc, lead and chromium and copper compared to 2006. Lower bacteriological levels in pipi were recorded in 2016 with no faecal coliform levels exceeding the value acceptable by the guidelines (although levels at two stations closest to the outfall within the plume were marginal).

### 3.4. Water

#### 3.4.1. Visual description of water samples

No floating matter such as scums, foams and other floatable material (other than twigs) or odour was observed at any of the water sampling stations. Water clarity at all stations was low and there were no conspicuous differences in water colour or clarity between the stations. As per the relevant consent requirements (condition 60 part II), no undesirable biological growths were observed either on the water surface or around the vicinity of the outfall while SCUBA diving.

#### 3.4.2. Metal/metalloids

No arsenic, cadmium, or mercury was detected in water at any of the stations (Table 5). Chromium was detected in the near-bed water samples at the mixing zone and estuary bar stations (0.0012 g/m<sup>3</sup>). Copper was recorded in near-bed samples at the mixing zone station as well as in near-surface and near-bed samples at the bar station (0.002, 0.0015 and 0.0028 g/m<sup>3</sup> respectively). Lead was recorded in the near-bed samples from all upstream, mixing zone and bar stations (0.0019, 0.0022 and 0.0045 g/m<sup>3</sup> respectively). Zinc was recorded from the near-bed upstream, the near-bed mixing zone and the near-surface and near-bed bar stations (0.0081, 0.0093, 0.0043 and 0.0179 g/m<sup>3</sup> respectively). Where guidelines exist, the concentrations of all metals (cadmium, chromium, copper, lead, mercury, nickel and zinc) were below the ANZECC (2000) trigger values for slightly to moderately disturbed marine water systems.

Table 5. Water metal/metalloid concentrations (g/m<sup>3</sup>) for near-surface (S) and near-bed (B) water samples from the three water sampling stations: upstream (US), mixing zone (MZ) and bar (B). ANZECC 2000 values are triggers for slightly to moderately disturbed systems in marine waters.

Site	Arsenic	Cadmium	Chromium	Copper	Lead	Mercury	Nickel	Zinc
<b>US-S</b>	< 0.0042	< 0.00021	< 0.0011	< 0.0011	< 0.0011	< 0.00008	< 0.007	< 0.0042
<b>US-B</b>	< 0.0042	< 0.00021	< 0.0011	< 0.0011	0.0019	< 0.00008	< 0.007	0.0081
<b>MZ-S</b>	< 0.0042	< 0.00021	< 0.0011	< 0.0011	< 0.0011	< 0.00008	< 0.007	< 0.0042
<b>MZ-B</b>	< 0.0042	< 0.00021	0.0012	0.002	0.0022	< 0.00008	< 0.007	0.0093
<b>B-S</b>	< 0.0042	< 0.00021	< 0.0011	0.0015	< 0.0011	< 0.00008	< 0.007	0.0043
<b>B-B</b>	< 0.0042	< 0.00021	0.0012	0.0028	0.0045	< 0.00008	< 0.007	0.0179
<b>ANZECC 2000</b>		0.7	27.4	1.3	4.4	0.1	7	15

#### 3.4.3. Nutrients, TSS and BOD

Total nitrogen concentrations were highest in the bar (0.85 g/m<sup>3</sup>) and mixing zone (0.36 g/m<sup>3</sup>) near-bed samples (Figure 12) and were above the ANZECC (2000) trigger value of 0.3 g/m<sup>3</sup> for physical and chemical stressors of slightly disturbed estuarine

ecosystems. The lowest ( $0.17 \text{ g/m}^3$ ) nitrogen concentration was recorded from the mixing zone near-surface sample. Total ammoniacal-N was highest ( $0.079 \text{ g/m}^3$ ) at the bar near-bed sample, this was below the ANZECC (2000) trigger value of  $0.015 \text{ g/m}^3$  for physical and chemical stressors of slightly disturbed estuarine ecosystems. Ammoniacal-N was below detection limit ( $< 0.01 \text{ g/m}^3$ ) in the upstream near-bed and near-surface and mixing zone near-surface samples. Phosphorus was highest ( $0.023 \text{ g/m}^3$ ) in the bar near-bed and lowest ( $0.0049 \text{ g/m}^3$ ) at the upstream near-bed samples.

Total suspended solids (TSS) were highest ( $33 \text{ g/m}^3$ ) in the bar near-bed sample and lowest ( $3 \text{ g/m}^3$ ) at the upstream near-surface sample (Figure 12). Nitrogen, ammoniacal-N, phosphorus and TSS values were higher in near-bed samples at the mixing zone station than at the upstream station and higher again at the bar station. In the near-surface samples these variables did not show any consistent spatial patterns but values were generally lower than in near-bed samples. Biological oxygen demand was below the detection limit ( $2 \text{ g O}_2/\text{m}^3$ ) in all water samples.

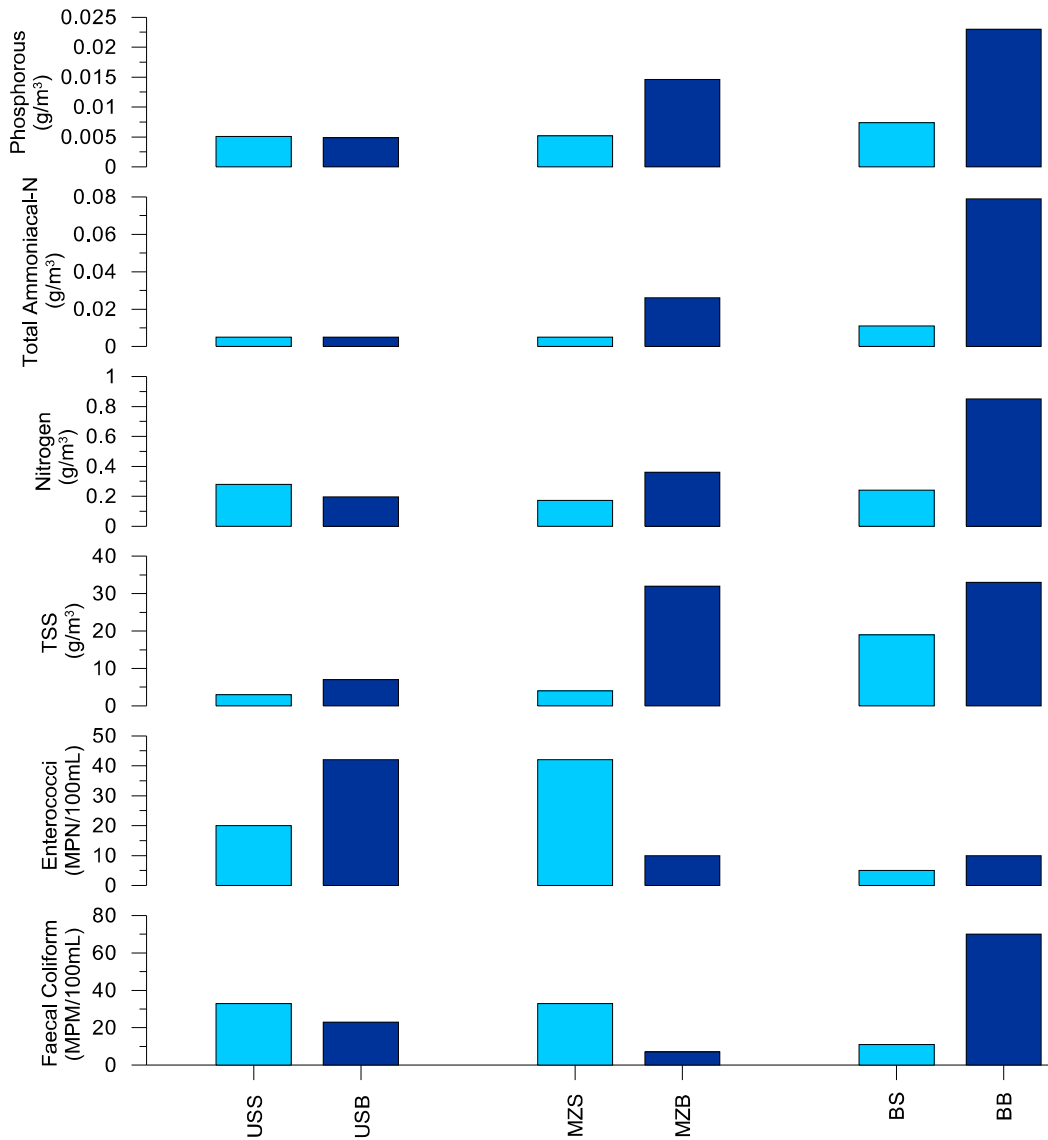

Figure 12. Water nutrient (nitrogen, total ammoniacal-N and dissolved reactive phosphorus) bacteriological results (faecal coliform and enterococci) and total suspended solids (TSS) for near-surface (S) and near-bed (B) water samples in 2016 from three stations at varying distances from the BSTP outfall: 400 m upstream (US), 300 m downstream mixing zone (MZ) and 550 m downstream bar (B). Note: total ammoniacal-N was below detection limits at some sites, where this occurred the value shown is half the detection limit.

### 3.4.4. Water bacteria

Concentrations of enterococci were highest in the upstream near-bed and mixing zone near-surface samples (42 MPN/100mL) and lowest in the near-surface sample at the bar station (< 10 MPN/100mL) (Figure 12). Concentrations in the near-bed upstream and near-surface mixing zone samples were lower than those that define



the limit for primary water contact in the ANZECC (2000) water quality guidelines (maximum of 60–100 organisms/100 mL in any single sample). All concentrations were well below those that would trigger the Alert/Amber mode action level of 140 enterococci/100 mL in a single sample as outlined in the MfE (2003) guidelines.

Faecal coliform concentrations were highest in the bar near-bed sample (70 MPN/100mL) and lowest in the mixing zone near-bed sample (7 MPN/100mL). All faecal coliform concentrations were lower than those that define the limit for primary water contact in the ANZECC (2000) water quality guidelines (median of 150 faecal coliform organisms/100mL).

#### 3.4.5. Water hydrological parameters

Salinity was highly variable, reflecting the various freshwater and marine water sources present in the estuary entrance (Table 6). The pH was relatively constant across the stations.

Table 6. Salinity and pH of near-surface and near-bed water samples in 2016 from three stations at varying distances from the BSTP outfall.

Water Quality Survey Site	Salinity (psu)	pH
Bar Surface	8.39	8.08
Bar Bed	26.78	8.06
Mixing Zone Surface	3.43	8.23
Mixing Zone Bed	28.92	8.16
Upstream Surface	3.38	8.02
Upstream Bed	3.61	7.92

Turbidity ranged between 6.0–9.7 NTU<sup>2</sup> at the mixing zone, between 7.8–9.7 NTU at the bar station and 3.5–4.7 NTU at the upstream station (Figure 13). The salinity profiles showed a surface layer of low-salinity water and the remainder of the water column well-mixed (no variation in salinity with depth) at the bar and mixing zone stations. The water column at the shallow upstream station was also well mixed and salinity was low, reflecting the dominance of freshwater flow on the ebbing tide.

In regards to the consent conditions relating to other water parameters:

- Temperature at the three stations ranged between 16.7–17.9 C° (Figure 13). It was therefore within the consent requirement (condition 59a Part II) of less than a

<sup>2</sup> Nephelometric Turbidity Units

3 C° natural temperature change within the receiving environment outside of the mixing zone.

- Dissolved oxygen ranged between 7.6–9.7 mg/L at the mixing zone station, 8.1–8.8 mg/L at the bar and 8.2–8.3 mg/L at the upstream station (Figure 13). Oxygen saturation did not drop below 86% at any of the stations (data from CTD instrument not shown) and the receiving water was therefore within the consent requirement (condition 59c Part II:  $\geq 80\%$  of saturation).
- No conspicuous change in colour or clarity associated with the discharge was visually observed and therefore the receiving water was assumed to be within the consent requirement (condition 59b Part II).

#### ***3.4.6. Comparison with 2006***

Water sampling at the receiving environment has not been previously conducted following the methodology used in the current survey and therefore no data were available to directly compare the 2016 results against.

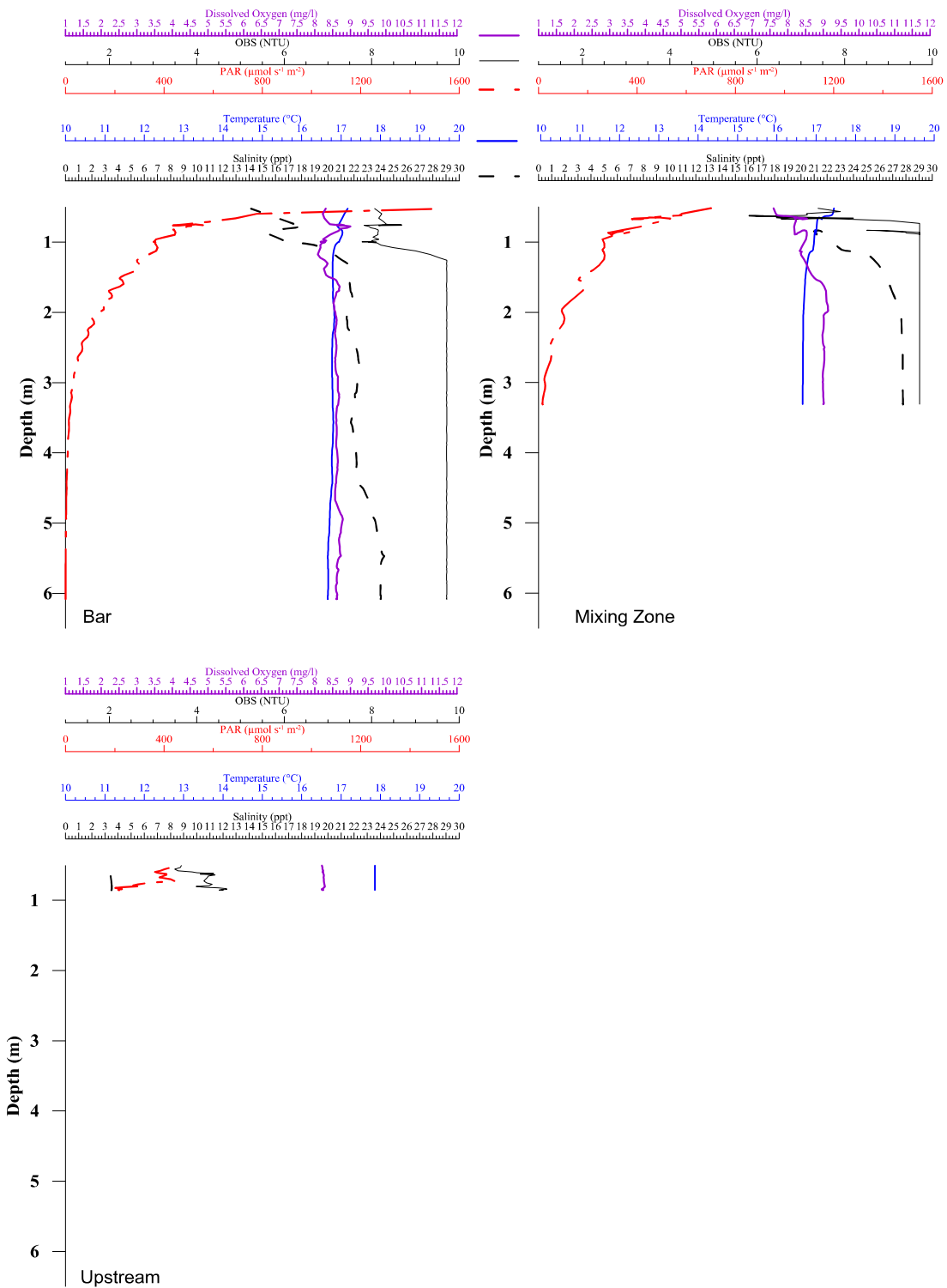

Figure 13. Hydrological profiles in 2016 from three stations at varying distances from the BSTP outfall: 400 m upstream (US), 300 m downstream in the mixing zone (MZ) and 550 m downstream at the bar entrance (B). The plots show values of dissolved oxygen, turbidity (as optical back-scatter, OBS), light (as photosynthetically active radiation, PAR), temperature and salinity over the range of water depth at each station (c. 6 m at the bar, c. 3.3 m in the mixing zone and c. 1 m upstream).

## 4. DISCUSSION

### 4.1. Ecological changes associated with the wastewater discharge

#### 4.1.1. Sediment

Compared to the results of Barter et al. (2006), in 2016 no changes likely to have adverse ecological effects were detected in sediment grain size and chemistry (metals/metalloids and organic content). In 2016 there were also no strong patterns in these sediment parameters in relation to the overall distance gradient downstream of the outfall and position inside and outside the plume. Therefore it is unlikely that the discharge from the outfall was strongly influencing these variables.

#### 4.1.2. Infauna

Compared to the 2006 results, infauna density was lower in 2016 and species richness, diversity and evenness values spread over a wider range. There was also some minor variation between the two surveys in infauna community patterns. However in 2016, with the exception of diversity and evenness which were generally lowest within the plume closest to the outfall, there were no strong patterns in relation to distance from the outfall and position inside and outside of the plume that would suggest an effect of the discharge. In regards to infauna composition, although there was a change in the identity of the dominant species at some sites, particularly the lack of dominance by the snail *Potamopyrgus estuarinus* in 2016, this is unlikely to be caused by the discharge as these changes occurred both within and outside the plume.

#### 4.1.3. Shellfish

Although in 2016 the concentrations of some metal/metalloids in shellfish were higher compared to 2006, all of these (except for arsenic) were below the ANZFSC (2015) guideline levels. Similar to 2006, nearly all arsenic concentrations in 2016 were above the ANZFSC (2015) guideline, although this occurred at nearly all stations and therefore could not be attributed to the discharge. All metal/metalloid concentrations were higher inside the plume, compared to outside, at the station < 5 m from the outfall. However, similar concentrations were also recorded at all stations outside the plume at 100 m downstream of the discharge, indicating that the discharge was not necessarily the source of these metals/metalloids. There were no other strong, consistent patterns of metal/metalloid concentrations in shellfish in relation to distance from the outfall and the position inside and outside the plume. Although faecal coliform levels in 2016 were slightly higher at the two stations closest to the outfall within the plume compared to all other stations, the levels were still within acceptable criteria for food (MoH 1995), and were only slightly higher than those outside the plume at a further distance from the outfall. Consequently, this potential impact of the discharge was not considered important.

#### 4.1.4. Water quality

Water sampling at the receiving environment had not been previously conducted following the methodology used in the current survey and therefore no data were available against which to compare the 2016 results.

In 2016 the applicable water metal concentrations at all stations were below the ANZECC (2000) guideline trigger values. However, the near-bed samples at the mixing zone and bar contained higher nitrogen, phosphorous, ammoniacal-N and TSS concentrations, than that at the upstream station. Nitrogen concentrations in the near-bed samples from the mixing zone and bar stations were also higher than the ANZECC (2000) trigger value. Although this is consistent with the outfall being a source of nutrients and suspended solids, these parameters were lower in the mixing zone compared to the estuary bar samples. It is therefore unlikely that the discharge from the BSTP outfall was the sole cause of these higher concentrations. BOD<sub>5</sub> at all water stations was below detectable levels and was therefore not considered to be influenced by the discharge.

While higher concentrations of enterococci were present at the mixing zone station in 2016 compared to 2006, similarly high concentrations were present at the upstream station. This indicates that the outfall discharge was unlikely to be the source. Although in the near-bed samples the highest faecal coliform level occurred at the bar station, the level at the mixing zone station was lower than at the bar and upstream stations, indicating that the main source of this was also unlikely to be the outfall discharge. In regards to the near-surface samples the levels at the upstream and mixing zone stations were similar and both higher than at the bar station, also indicating that the outfall discharge was unlikely to be the main source of this.

Dissolved oxygen levels and water temperature in 2016 were comparable amongst all of the three water quality stations and therefore the discharge did not appear to have affected these variables.

In 2016, turbidity levels were similar at the bar and mixing zone stations, and were higher than the upstream station. It is possible that the elevation in turbidity was caused by the wastewater discharge. It is also possible that changes in hydrodynamics and current speed contributed to the increased turbidity at the bar and mixing zone.

There were no detected breaches of the water quality conditions in the discharge consent in 2016. It is recommended that future water quality surveys also sample water on the Vernon Lagoons side upstream of the outfall on the ebb tide to get a more complete picture of water quality within the area.

## 4.2. Summary

Overall, although some minor environmental and ecological differences were apparent between the 2006 and 2016 surveys, no adverse ecological effects of the BSTP discharge (and no breaches of the water quality consent conditions) were detected overall. The lack of significant adverse effects on receiving water or bed sediment quality is likely due to the quality of the discharge, coupled with high initial dilution and rapid flushing during the ebb tide-only discharge (CH2M Beca 2014).

## 5. ACKNOWLEDGMENTS

Thank you to Stuart Donaldson from Marlborough District Council for the provision of background information and to Paul Meredith from the Cawthron Institute for assistance in the field. The Cawthron Institute taxonomy team, led by Fiona Gower, undertook the infauna taxonomic identification work.

## 6. REFERENCES

- ANZECC 2000. Australian and New Zealand Guidelines for Fresh and Marine Water Quality 2000 Volume 1 and 2. National Water Quality Management Strategy Paper No 4. Australian and New Zealand Environment and Conservation Council and Agriculture and Resource Management Council of Australia and New Zealand, Canberra.
- ANZFSC 2015. Standard 1.4.1, Contaminants and natural toxicants. Australia New Zealand Food Standards Code.
- Barter P, Sneddon R, Bennet C 2006. Ecological investigations into discharge options to water for the MDC sewage treatment plant, Blenheim. Prepared for Marlborough District Council. Cawthron Report No. 1161. 92 p plus appendices.
- CH2M Beca 2007. Assessment of environmental effects for the upgraded Blenheim sewage treatment plant 2007. Prepared for Marlborough District Council by CH2M Beca Ltd.
- CHM2 Beca Limited 2014. Blenheim sewage treatment plant annual consent compliance report—1 July 2014—30 June 2015. Prepared for Marlborough District Council.
- Clarke KR, Gorley RN 2001. PRIMER v5: User manual/tutorial. Plymouth Marine Laboratory, United Kingdom.
- Clarke KR, Warwick RM 1994. Change in marine communities: An approach to statistical analysis and interpretation. Plymouth Marine Laboratory, United Kingdom.
- Kruskal JB, Wish M 1978. Multidimensional scaling. Sage Publications, Beverley Hills, California.
- MfE 2003. Microbiological water quality guidelines for marine and freshwater recreational areas. Ministry for the Environment, Wellington.
- MoH 1995. Microbiological reference criteria for food. New Zealand Ministry of Health. October 1995.

## 7. APPENDICES

Appendix 1. Consent (U071181) conditions 58, 59 (a-c) and 60 G (Part II).

**58.** The proposed mixing zone for the discharge to the Wairau Estuary shall be as shown on Plan No D in Appendix 1 to these consent conditions.

**59.** The discharge of treated wastewater from the upgraded BSTP shall not cause any of the following effects outside the mixing zone described in Condition 58 above:

- a) The natural temperature of the receiving water to change by more than 3 degrees Celsius;
- b) Any conspicuous change in colour or clarity of the receiving water such that visual clarity of water is reduced by more than 50% as per the Water Quality Guidelines No 2 Ministry for the Environment (1994);
- c) The concentration of dissolved oxygen of the receiving water to fall below 80 percent of the saturation content.

**60.** There shall be no undesirable biological growths as a result of the discharge.



Appendix 2. Locations (in decimal degrees) of 2016 benthic survey stations in the Wairau Estuary.

<b>Station code</b>	<b>Location</b>	<b>Latitude</b>	<b>Longitude</b>
OF P	Outside plume, <5m from outfall	-41.50520712	174.0582631
25DS P	Outside plume, 25m downstream	-41.50502551	174.0584279
50DS P	Outside plume, 50m downstream	-41.50483566	174.0585087
100DS P	Outside plume, 100m downstream	-41.50455141	174.0590671
200DS P	Outside plume, 200m downstream	-41.50387725	174.0599187
300DS P	Outside plume, 300m downstream	-41.50315004	174.0606616
OF O	Inside plume, <5m from outfall	-41.50526223	174.0581442
25DS O	Inside plume, 25m downstream	-41.50537633	174.0584695
50DS O	Inside plume, 50m downstream	-41.50477504	174.0582442
100DS O	Inside plume, 100m downstream	-41.50433101	174.0585485
200DS O	Inside plume, 200m downstream	-41.50357571	174.0594107
300DS O	Inside plume, 300m downstream	-41.50283061	174.0601414

Appendix 3. Locations (in decimal degrees) of 2016 water sampling stations in Wairau the Estuary.

<b>Station code</b>	<b>Location</b>	<b>Latitude</b>	<b>Longitude</b>
US	400 m upstream of outfall	-41.504611	174.05375
MZ	300 m downstream of outfall	-41.503369	174.059906
B	550 m downstream of outfall	-41.501289	174.061192

Appendix 4. Sediment core photos.

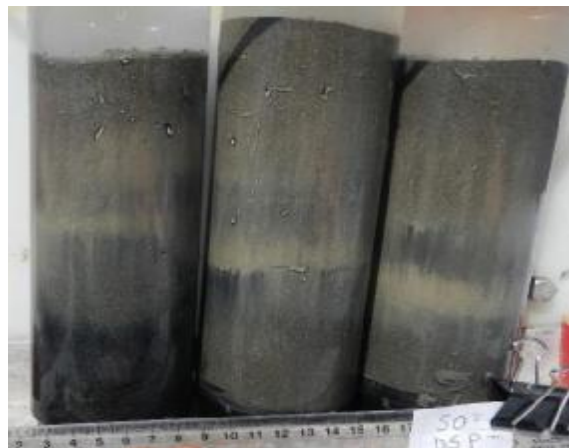
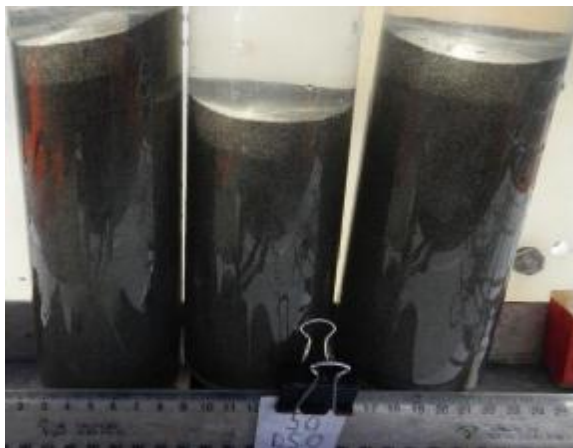
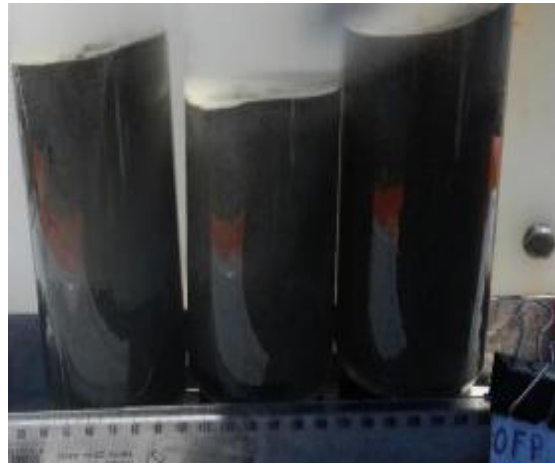

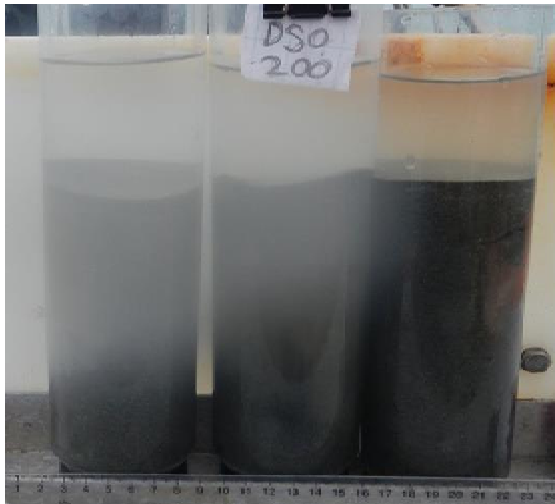
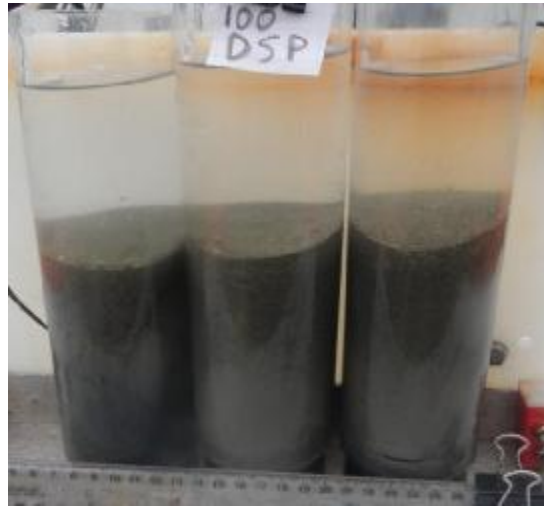
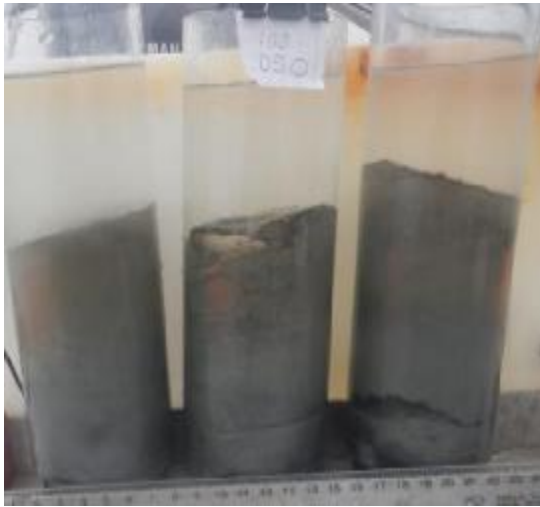

Appendix 5. Infauna data from all benthic survey stations.

GenGroup	Taxa	25DSO, A	25DSO, B	25DSO, C	25DSP, A	25DSP, B	25DSP, C	50DSO, A	50DSO, B	50DSO, C	50DSP, A	50DSP, B	50DSP, C	100DSO, A	100DSO, B	100DSO, C	100DSP, A	100DSP, B	100DSP, C	200DSO, A	200DSO, B	200DSO, C	200DSP, A	200DSP, B	200DSP, C	300DSO, A	300DSO, B	300DSO, C	300DSP, A	300DSP, B	300DSP, C	OFO, A	OFO, B	OFO, C	OFF, A	OFF, B	OFF, C		
Hydrozoa	Hydrozoa	1	1	1																				1															
Nemertea	Nemertea											1			1									1	1					4									
Nematoda	Nematoda													1	1																								
Gastropoda	<i>Amphibola</i> sp.																					9																	
Gastropoda	<i>Austrofusus glans</i>																						2	2	2														
Gastropoda	<i>Notoacmea helmsi</i>																						1																
Gastropoda	<i>Potamopyrgus estuarinus</i>	11	5	4		2						2	1	7	3	21			1				6	4	3				1	4		3	2	8	1	1	1	1	
Bivalvia	Bivalvia Unid. (juv)													2			1				1								1										
Bivalvia	Mussel Spat														1																								
Bivalvia	<i>Arthritica bifurca</i>														3	1	2	2	1										3			1							
Bivalvia	<i>Austrovenus stutchburyi</i>			1				1																															
Bivalvia	<i>Paphies australis</i>	1				2	1	2	3	3	1	1	2	8	5	7	2	6	10	2	2	3	14	8	13	1	2					1	3	5	3	2			1
Bivalvia	<i>Xenostrobus pulex</i>			1																																			
Oligochaeta	Oligochaeta		1	4		2									3			1		2									3	2				1					
Polychaeta	Polydorid		5																														1						
Polychaeta	<i>Scoloplos</i> sp.			1																																			
Polychaeta	<i>Prionospio aucklandica</i>	9		7	4	3								1		3			1				6	17	7		1	1	1				1						
Polychaeta	<i>Prionospio</i> sp.					1									1								2	3	7				1										
Polychaeta	<i>Scolecopides freemani</i>	1	2	1																																			
Polychaeta	<i>Scolelepis</i> sp.	1	1	2		2					1				1	16	15	27	1		2												3	2	4	1	8	3	
Polychaeta	<i>Barantolla lepte</i>													2																									
Polychaeta	<i>Capitella capitata</i>	4	2		4	11	8		1		8	3		6	4	13	13	11	19	1			2	3	2				3		1	4	4	13				2	
Polychaeta	<i>Heteromastus filiformis</i>	5	12	6	1	1	3							10	5	12	13	7	8	9	11	9	5	4	3			25	47	40	4			2					
Polychaeta	Maldanidae	2																																					
Polychaeta	Hesionidae																		1																				
Polychaeta	Syllidae	1	5	13																																			
Polychaeta	Nereididae (juvenile)	1			1	1	1					1					1		1				1	1				1			1		3	4	2	1			
Polychaeta	<i>Ceratonereis</i> sp.		2		3	2	1																															1	
Polychaeta	<i>Nicon aestuariensis</i>													2																									

GenGroup	Taxa	25DSO, A	25DSO, B	25DSO, C	25DSP, A	25DSP, B	25DSP, C	50DSO, A	50DSO, B	50DSO, C	50DSP, A	50DSP, B	50DSP, C	100DSO, A	100DSO, B	100DSO, C	100DSP, A	100DSP, B	100DSP, C	200DSO, A	200DSO, B	200DSO, C	200DSP, A	200DSP, B	200DSP, C	300DSO, A	300DSO, B	300DSO, C	300DSP, A	300DSP, B	300DSP, C	OFO, A	OFO, B	OFO, C	OFF, A	OFF, B	OFF, C					
Polychaeta	Goniadidae			1	1													1	1																							
Polychaeta	Cirratulidae	2																																								
Polychaeta	Serpulidae	1																																								
Crustacea	Mysidacea							1				1					1	2	1		1	7				2	2					1										
Isopoda	Munnidae	1		3																																						
Isopoda	<i>Uromunna schauinslandi</i>																																									
Amphipoda	Corophiidae	7	163	94	124	127	160	3	2	7	313	276	460	235	101	43	39	51	70	49	94	126	21	17	1	1	4	122	182	242	651	177	258	316	409	584						
Amphipoda	Amphipoda	49	133	53	257	221	313	5	3	1	206	176	383	60	227	105	1	9	12	161	21			27	17	1	2	157	348	261	117	162	84	245	85	11						
Decapoda	<i>Halicarcinus cookii</i>																																									
Decapoda	<i>Hemigrapsus crenulatus</i>	6	8	8																		2																				
Decapoda	<i>Hemiplax hirtipes</i>		1		1									2	7	2																										
Decapoda	Brachyura Unid.																																									
Decapoda	Decapoda (Juvenile/larvae unid.)																																									
Decapoda	(Juvenile/larvae unid.)		1	1																																						
Copepoda	Copepoda																																									
Cirripedia	<i>Austrominius modestus</i>	268	220	181										3	4							1	194	225	163																	
Pycnogonida	Pycnogonida																																									

Appendix 6. One-way SIMPER analysis based on Bray Curtis similarity (with a 70% cut off for low contributions) of infauna communities from all benthic survey stations in Wairau Estuary (n=3).

<b>Station: ODSO</b>					
Average similarity: 73.48					
Species	Av.Abund	Av.Sim	Sim/SD	Contrib%	Cum.%
Corophiidae	18.29	31.82	27.27	43.3	43.3
Amphipoda	10.9	21.89	7.09	29.79	73.08

<b>Station: ODSP</b>					
Average similarity: 75.16					
Species	Av.Abund	Av.Sim	Sim/SD	Contrib%	Cum.%
Corophiidae	20.72	51.75	8.36	68.86	68.86
Amphipoda	9.4	14.4	1.68	19.15	88.01

<b>Station: 25DSO</b>					
Average similarity: 71.12					
Species	Av.Abund	Av.Sim	Sim/SD	Contrib%	Cum.%
<i>Austrominius modestus</i>	14.89	24.99	13.04	35.14	35.14
Amphipoda	8.6	12.73	29.71	17.9	53.04
Corophiidae	8.37	8.75	1.3	12.31	65.34
<i>Hemigrapsus crenulatus</i>	2.7	4.61	22.47	6.49	71.83

<b>Station: 25DSP</b>					
Average similarity: 84.71					
Species	Av.Abund	Av.Sim	Sim/SD	Contrib%	Cum.%
Amphipoda	16.2	39.49	13.47	46.62	46.62
Corophiidae	11.68	28.91	38.85	34.13	80.75

<b>Station: 50DSO</b>					
Average similarity: 69.15					
Species	Av.Abund	Av.Sim	Sim/SD	Contrib%	Cum.%
<i>Paphies australis</i>	1.63	24.76	4.73	35.8	35.8
Corophiidae	1.93	24.54	8.31	35.48	71.29

<b>Station: 50DSP</b> Average similarity: 83.33					
Species	Av.Abund	Av.Sim	Sim/SD	Contrib%	Cum.%
Corophiidae	18.58	43.46	20.3	52.16	52.16
Amphipoda	15.73	34.89	19.98	41.87	94.03

<b>Station: 100DSO</b> Average similarity: 66.45					
Species	Av.Abund	Av.Sim	Sim/SD	Contrib%	Cum.%
Amphipoda	11.02	20.08	6.04	30.22	30.22
Corophiidae	10.65	17.98	4.48	27.06	57.28
<i>Heteromastus filiformis</i>	2.95	6	3.9	9.03	66.31
<i>Paphies australis</i>	2.57	5.57	6.9	8.39	74.7

<b>Station: 100DSP</b> Average similarity: 77.35					
Species	Av.Abund	Av.Sim	Sim/SD	Contrib%	Cum.%
Corophiidae	7.25	22.87	19.04	29.57	29.57
Scolelepis sp.	4.36	13.72	13.12	17.74	47.31
<i>Capitella capitata</i>	3.76	11.96	12.22	15.46	62.77
<i>Heteromastus filiformis</i>	3.03	9.49	12.69	12.26	75.04

<b>Station: 200DSO</b> Average similarity: 59.48					
Species	Av.Abund	Av.Sim	Sim/SD	Contrib%	Cum.%
Corophiidae	9.31	32.52	3.9	54.68	54.68
<i>Heteromastus filiformis</i>	3.11	12.26	17.31	20.62	75.3

<b>Station: 200DSP</b> Average similarity: 79.15					
Species	Av.Abund	Av.Sim	Sim/SD	Contrib%	Cum.%
<i>Austrominius modestus</i>	13.9	33.85	21.74	42.76	42.76
<i>Paphies australis</i>	3.39	7.99	4.94	10.1	52.86
<i>Prionospio aucklandica</i>	3.07	6.47	18.81	8.18	61.04
Corophiidae	3.24	5.16	1.17	6.52	67.56
<i>Potamopyrgus estuarinus</i>	2.06	4.68	15.11	5.92	73.48



<b>Station: 300DSO</b>					
Average similarity: 25.25					
Species	Av.Abund	Av.Sim	Sim/SD	Contrib%	Cum.%
Mysidacea	0.94	8.09	0.58	32.04	32.04
<i>Paphies australis</i>	0.8	5.72	0.58	22.65	54.69
Corophiidae	1	5.72	0.58	22.65	77.35

<b>Station: 300DSP</b>					
Average similarity: 72.87					
Species	Av.Abund	Av.Sim	Sim/SD	Contrib%	Cum.%
Amphipoda	15.78	29.51	21.48	40.5	40.5
Corophiidae	13.36	25.53	67.02	35.04	75.54

Appendix F

## Nitrogen Load to Land

Irrigation Area	Annual Nitrogen Load per Area (kg/ha)
DLA-01	117.3
DLA-02	28.2
DLA-03	27.5
DLA-04	20.7
DLA-05	42.2
DLA-06	20.7
DLA-07	60.7
KLA-01 Nth	13.0
KLA-01 Sth	118.3
KLA-02 Nth	61.9
KLA-02 Sth	49.0
KLA-03 Nth	76.0
KLA-03 Sth	63.9
KLA-04 Nth	56.5
KLA-04 Sth	75.7
KLA-05	68.8
KLA-06 Nth	11.0
KLA-06 Sth	123.6
KLA-07	70.1

KLA-08 Nth	40.5
KLA-08 Sth	52.4
KLA-09 Nth	87.6
KLA-09 Sth	3.6
KLA-10 Nth	0.0
KLA-10 Sth	93.4
KLA-11 Nth	2.1
KLA-11 Sth	103.1
KLA-12 East	0.4
KLA-12 West	36.7
KLA-13 East	72.3
KLA-13 West	7.6
KLA-14	76.7